

T.D. 8824

**DEPARTMENT OF THE TREASURY
Internal Revenue Service
26 CFR Parts 1 and 602**

Regulations Under Section 1502 of the Internal Revenue Code of 1986; Limitations on Net Operating Loss Carryforwards and Certain Built-in Losses and Credits Following an Ownership Change of a Consolidated Group

AGENCY: Internal Revenue Service (IRS), Treasury.

ACTION: Final and temporary regulations.

SUMMARY: This document contains final regulations regarding the operation of sections 382 and 383 of the Internal Revenue Code of 1986 (relating to limitations on net operating loss carryforwards and certain built-in losses and credits following an ownership change) with respect to consolidated groups. The regulations include rules for determining whether a loss group or a loss subgroup has an ownership change, for computing a consolidated section 382 limitation or subgroup section 382 limitation, and for applying sections 382 and 383 to corporations that join or leave a group. The rules are necessary to provide guidance to such groups on the use of certain of their tax attributes.

DATES: *Effective Dates:* These regulations are effective June 25, 1999.

Applicability Dates: For dates of application and special effective date rules, see Effective Dates under SUPPLEMENTARY INFORMATION.

FOR FURTHER INFORMATION CONTACT: Lee A. Kelley at (202) 622-7550 (not a toll-free number).

SUPPLEMENTARY INFORMATION:

Paperwork Reduction Act

The collection of information in these final regulations has been reviewed and, pending receipt and evaluation of public comments, approved by the Office of

Management and Budget (OMB) under 44 U.S.C. 3507 and assigned control number 1545-1218.

The collections of information in this regulation are in §§1.1502-20(g)(4), 1.1502-95(e)(8), 1.1502-95(f), and 1.1502-96(e). This information is required to assure that a section 382 limitation is properly determined and applied in cases of corporations that become or cease to be members of a consolidated group. The collection of information in §1.1502-98(e)(8) is mandatory. The other collections of information are required to obtain a benefit. The likely respondents are business or other for-profit institutions.

Comments on the collection of information should be sent to the **Office of Management and Budget**, Attn: Desk Officer for the Department of the Treasury, Office of Information and Regulatory Affairs, Washington, DC 20503, with copies to the **Internal Revenue Service**, Attn: IRS Reports Clearance Officer, OP:FS:FP, Washington, DC 20224. Comments on the collection of information should be received by August 31, 1999. Comments are specifically requested concerning:

Whether the collection[s] of information is necessary for the proper performance of the functions of the **Internal Revenue Service**, including whether the information will have practical utility;

The accuracy of the estimated burden associated with the collection of information (see below);

How the quality, utility, and clarity of the information to be collected may be enhanced;

How the burden of complying with the collection[s] of information may be minimized, including through the application of automated collection techniques or other forms of information technology; and

Estimates of capital or start-up costs and costs of operation, maintenance, and purchase of service to provide information.

Estimated total annual reporting burden: 662 hours.

The estimated annual burden per respondent varies from 15 to 25 minutes, depending on individual circumstances, with an estimated average of 20 minutes.

Estimated number of respondents: 12,054

Estimated annual frequency of responses:

On occasion

An agency may not conduct or sponsor, and a person is not required to respond to, a collection of information unless it displays a valid control number assigned by the Office of Management and Budget.

Books or records relating to a collection of information must be retained as long as their contents may become material in the administration of any internal revenue law. Generally, tax returns and tax return information are confidential, as required by 26 U.S.C. 6103.

Background

On February 4, 1991, the IRS and Treasury issued three notices of proposed rulemaking, CO-132-87 (56 F.R. 4194 [1991-1 C.B. 728]), CO-077-90 (56 F.R. 4183 [1991-1 C.B. 749]), and CO-078-90 (56 F.R. 4228 [1991-1 C.B. 757]), setting forth rules regarding the application of sections 382 and 383 by consolidated groups and by controlled groups, and regarding the use of built-in deductions and net operating losses and capital losses, including the carryover and carryback of separate return limitation year (SRLY) losses of members of consolidated groups. A public hearing regarding the three sets of proposed regulations was held on April 8, 1991.

On June 27, 1996, the IRS and Treasury published temporary regulations (T.D. 8678, 61 F.R. 33335 [1996-2 C.B. 134]) setting forth rules regarding the application of section 382 to affiliated groups of corporations filing consolidated returns. These regulations were substantially identical to the proposed regulations. A notice of proposed rulemaking cross-referencing the temporary regulations was published in the **Federal Register** on the same day (CO-026-96, 61 F.R. 33391 [1996-2 C.B. 440]) and the proposed regulations published in 1991 were withdrawn. The IRS and Treasury also published temporary regulations regarding the SRLY limitation (T.D. 8677, 61 F.R. 33321 [1996-2 C.B. 119]), and controlled group losses (T.D. 8679, 61 F.R. 33313 [1996-2 C.B. 25]). Notices of proposed rulemaking cross-referencing these temporary regulations were published on the same day (CO-025-96, 61 F.R. 33395 [1996-2 C.B. 439] and CO-024-96, 61 F.R. 33393 [1996-2 C.B. 437]) and the proposed regulations published in 1991 were withdrawn.

This Treasury decision adopts the 1996 proposed regulations regarding the application of section 382 to affiliated groups of corporations filing consolidated returns. The principal changes to those proposed regulations are described below.

As companions to this Treasury decision, the IRS and Treasury also are issuing final regulations relating to the application of sections 382 and 383 by members of controlled groups, and relating to the SRLY limitation. See T.D. 8823 on page 34 and T.D. 8825, 1999-28 I.R.B. 19.

Explanation of Provisions

A. Overview

1. Sections 382 and 383

Under section 382, if an ownership change occurs with respect to a loss corporation (as defined in section 382 and the regulations thereunder), the amount of the loss corporation's taxable income for a post-change year that may be offset by the net operating losses of the loss corporation arising before the ownership change is limited by an amount known as the section 382 limitation. The section 382 limitation for a taxable year of a loss corporation after an ownership change generally is equal to the fair market value of the corporation's stock immediately before the ownership change multiplied by the long-term tax exempt rate (a rate of return published periodically in the Internal Revenue Bulletin). See generally sections 382(b), (e), and (f). This limitation for a taxable year may be increased by certain items, such as an unused limitation from a prior taxable year and certain built-in gains recognized during the taxable year. See section 382(b)(2) and (h).

In general, an ownership change involves an increase of more than 50 percentage points in stock ownership by 5-percent shareholders during the testing period (usually the 3-year period ending on the date on which a loss corporation must make a determination whether it has had an ownership change). In determining whether an ownership change has occurred, all transactions occurring during the testing period that affect the stock ownership of any 5-percent shareholder whose percentage of stock ownership has increased as of the close of the testing date are taken into account. The determination of the percentage ownership inter-

est of any shareholder is made on the basis of the ratio of the fair market value of the loss corporation stock owned by the shareholder to the total fair market value of the loss corporation's outstanding stock. Ordinarily, all stock of the loss corporation, except certain preferred stock described in section 1504(a)(4), is taken into account. These rules are contained in §§1.382-2 and 1.382-2T and relate to ownership changes of corporations without regard to whether the corporations file a separate return or join in filing a consolidated return.

2. General Description of Final Regulations

This document contains two sets of rules. The first set of rules, set forth in §§1.1502-91 through 1.1502-93, provide the tax treatment for net operating losses that arise in (and net unrealized built-in losses with respect to) years that are not separate return limitation years with respect to a consolidated group. (A separate return limitation year, or SRLY, generally is a taxable year of a subsidiary in which the subsidiary was not a member of the group). In general, these rules adopt a single entity approach to determine ownership changes and the section 382 limitations with respect to such losses.

These final regulations also extend the single entity approach to loss subgroups within consolidated groups. A loss subgroup generally consists of two or more corporations that continue to be affiliated with each other after leaving one group and joining another where at least one of the corporations carries over losses from the first group to the second group. Thus, the single entity approach under the final regulations can apply, for example, to a consolidated group's acquisition of another consolidated group or of a chain of subsidiaries from another group.

The second set of rules, set forth in §§1.1502-94 and 1.1502-95, applies to corporations that join or leave a consolidated group with respect to certain attributes (e.g., attributes other than those arising in a consolidated return year). In general, section 382 is applied separately with respect to those attributes because the attributes cannot be used by other members. Section 1.1502-96 contains miscellaneous rules.

In general, §1.1502-98 provides that the rules contained in §§1.1502-91

through 1.1502–96 also apply for purposes of section 383, with adjustments to reflect that section 383 applies to credits and net capital losses.

B. Amendments to the Proposed Regulations

1. Definition of a Loss Subgroup, §1.1502–91(d)

Under the proposed regulations, a loss subgroup is composed of members of one group (the former group) that become members of another consolidated group. In the case of a net operating loss carryover, the members of a group compose a loss subgroup if (i) they were affiliated with each other in another group, (ii) they bear a relationship to each other described in section 1504(a)(1) immediately after they become members of the group (the subgroup parent requirement), and (iii) at least one of the members carries over a net operating loss arising in a year that is not a SRLY (and is not treated as a SRLY under proposed §1.1502–21(c)) with respect to the former group. In the case of a net unrealized built-in loss (NUBIL), the members of a group compose a loss subgroup if they (i) have been continuously affiliated with each other for the 5 consecutive year period ending immediately before they become members of the group (the five-year affiliation requirement), (ii) meet the subgroup parent requirement, and (iii) have, in the aggregate, a NUBIL. A member ceases to be included in a loss subgroup when it files a separate return, or when a member breaks the relationship described in section 1504(a)(1) to the loss subgroup parent, regardless of whether that member leaves the current group or remains in the consolidated group.

Retention of the subgroup parent requirement in general

Commentators suggested that the final regulations should eliminate the subgroup parent requirement in order to provide a single subgroup definition for the SRLY limitation and for the section 382 limitation. Other commentators recommended eliminating the requirement following an ownership change of the loss subgroup.

Like a loss group, a loss subgroup has an ownership change if the loss subgroup parent has an ownership change (the par-

ent change method). The parent change method, adopted for its administrative simplicity, looks only to ownership shifts of the parent corporation in determining whether the consolidated group (or loss subgroup) has an ownership change. Owner shifts of minority stock of subsidiary members are not taken into account. Application of the parent change method to loss subgroups eliminates the administrative burdens associated with a rule that would mandate separate tracking of the minority stock of each subgroup member for determining whether an ownership change of the loss subgroup has occurred.

The IRS and the Treasury have determined that, in circumstances where owner shifts of a loss subgroup must continue to be tracked, the parent change method should continue to apply for determining whether a subgroup has an ownership change. Accordingly, in general, these final regulations retain the subgroup parent requirement. Also, these final regulations retain the general rule that a member ceases to be a member of the loss subgroup on the first day that it ceases to bear a relationship described in section 1504(a)(1) to the loss subgroup parent. The final regulations, however, provide an election to treat the subgroup parent requirement as satisfied, and provide certain exceptions for ceasing to be a member of a loss subgroup when a member breaks the relationship described in section 1504(a)(1) to the loss subgroup parent, but remains within the current consolidated group.

Election to treat subgroup parent requirement as satisfied

The subgroup parent requirement may preclude subgroup treatment in instances where single entity principles make such treatment conceptually appropriate. For example, brother-sister corporations with net operating loss carryovers that are not SRLY losses with respect to the former group are not a loss subgroup even if the same acquirer acquires both corporations at the same time. However, single entity principles support treating the brother-sister corporations as a subgroup because they were affiliated with each other in the former group and remain affiliated in the current group.

To extend single entity treatment in such cases would require a mechanism other than the parent change method to track owner shifts of the loss subgroup. Some commentators suggested permitting the parent of the current group to designate the subgroup parent. Under this approach, such designation would be respected unless the designation is made with a principal purpose of avoiding an ownership change.

The IRS and the Treasury believe that the ability to designate the subgroup parent presents opportunities for avoiding or lessening the impact of section 382. Also, a principal purpose standard is not an effective mechanism for preventing inappropriate designations because the *only* purpose of such designation is to apply the ownership change rules of section 382.

The IRS and Treasury recognize, however, that it is appropriate to extend subgroup treatment to the extent that single entity principles support such treatment, and to the extent that subgroup treatment does not compromise the determination whether a subgroup has an ownership change. Also, the IRS and Treasury recognize that, in certain circumstances, taxpayers may prefer more stringent ownership change rules if they can obtain the benefit of subgroup treatment. Finally, the IRS and Treasury recognize that the ability of brother-sister corporations to constitute a section 382 subgroup may be necessary in order for section 382 subgroups to conform with SRLY subgroups, thus permitting application of the rule that eliminates a separate SRLY limitation where the application of SRLY and section 382 overlap. See §§1.1502–15(g), 1.1502–21(g) and 1.1502–22(g).

Accordingly, these final regulations provide that two or more corporations that become members of a consolidated group at the same time and that were affiliated with each other immediately before becoming members of the group are deemed to meet the subgroup parent requirement immediately after they become members of the group if the common parent of the acquiring group makes an election under §1.1502–91(d)(4) with respect to those members. An election includes all corporations that become members of the current group at the same time and that were affiliated with each other immediately before they become members of the current

group. The election applies solely for purposes of satisfying the subgroup parent requirement, and does not apply in determining whether members meet the other requirements for inclusion in a loss subgroup. Although the election applies solely for purposes of §§1.1502–91 through 1.1502–96 and §1.1502–98, the election may affect whether a SRLY limitation overlaps with application of section 382.

If the common parent makes an election under §1.1502–91(d)(4), each of the members with respect to which the election is made (and that is included in the loss subgroup) is treated as the loss subgroup parent for purposes of determining if the loss subgroup has an ownership change on, or after, becoming members of the current group. If, however, a member with respect to which the election is made has an ownership change upon (or after) ceasing to be a member of the current group, that ownership change does not cause an ownership change of a loss subgroup comprised of one or more of its members that remain members of the current group.

Exceptions for ceasing to be a member of a loss subgroup when a member breaks the section 1504(a)(1) relationship with the loss subgroup parent, §1.1502–95(d)(1)

In general, under §1.1502–95(d)(1)(ii), these final regulations provide that a member ceases to be a member of the loss subgroup on the first day that it ceases to bear a relationship described in section 1504(a)(1) to the loss subgroup parent. Continued affiliation through a loss subgroup parent is central to the operation of the parent change method to loss subgroups.

Under certain circumstances, however, separate tracking of the loss subgroup parent terminates, eliminating the need for members to maintain a section 1504(a)(1) relationship through a loss subgroup parent. Section 1.1502–96(a) provides, in part, that ownership shifts of a loss subgroup cease to be separately tracked if there is an ownership change of the loss subgroup within six months before, on, or after becoming members of the group, or if a period of five years elapses after becoming members of group during which

time the loss subgroup does not have an ownership change (a fold-in event).

Also, an election under §1.1502–91(d)(4) obviates the need for a section 1504(a)(1) relationship through a loss subgroup common parent because each member is separately tracked as if it were the loss subgroup parent.

In circumstances where the necessity of a section 1504(a)(1) relationship through a loss subgroup parent is eliminated, the IRS and the Treasury believe that a subgroup member should not cease to be a member of the subgroup solely because it ceases to bear such a relationship. Accordingly, these final regulations provide two exceptions to the general rule of §1.1502–95(d)(1)(ii). The first exception applies to the members of the loss subgroup if an election under §1.1502–91(d)(4) applies to them. The second exception applies to loss subgroup members following a fold-in event.

Members excluded or included from a subgroup with a principal purpose of avoiding a limitation, §1.1502–91(d)(5)

Proposed §1.1502–91(d)(5) provides that corporations do not compose a loss subgroup if any one of them is formed, acquired, or availed of with a principal purpose of avoiding the application of, or increasing any limitation under, section 382. This rule does not apply solely because, in connection with becoming members of the group, the members of a group are rearranged to satisfy the subgroup parent requirement. The final regulations retain these provisions, and, in conformity with the anti-abuse rule for SRLY subgroups, provide that any member excluded from a loss subgroup, if excluded with a principal purpose of avoiding or increasing a section 382 limitation, is treated as included in the loss subgroup. This rule does not apply solely because a group does not rearrange members of a group to satisfy the subgroup parent requirement.

2. Definition of Loss Subgroup with a NUBIL, §1.1502–91(d)(2)

Commentators criticized the five-year affiliation requirement for adding complexity to the regulations. For instance, the five-year affiliation requirement can cause application of section 382 and

SRLY on a single entity basis with respect to members of a loss subgroup with a net operating loss carryover that arose within the former group (because an NOL loss subgroup does not require five years of affiliation), but on a separate entity basis for those same members with respect to built-in losses.

The IRS and Treasury have determined, however, that the five-year affiliation requirement is a necessary feature of the NUBIL subgroup rules. Just as the NOL subgroup rules apply only to loss carryovers that arise in (or have folded into) the former group, so should the NUBIL subgroup rules apply only to built-in losses that accrue within (or have folded into) the former group. Because an accurate method of determining economic accrual (*e.g.*, tracing) would present significant problems for tax administration and for compliance by taxpayers, the IRS and Treasury believe that the five-year affiliation requirement is the best available proxy for determining when built-in attributes arise.

Absent a five-year affiliation requirement, taxpayers could effectively traffic in net unrealized built-in losses without being subject to any limitation (other than one imposed under an applicable “principal purpose” anti-abuse rule). A selling group could acquire a new member with a NUBIG and sell both that recently-acquired NUBIG member and the member containing the desired NUBIL to the prospective buyer. To the extent that the NUBIG offset the NUBIL and the corporations were structured to satisfy the requirements for subgroup treatment, recognized built-in losses would escape any limitation and could be freely absorbed by the acquiring group.

Furthermore, the absence of a five-year affiliation requirement could be used to circumvent a SRLY limitation applicable to a NUBIL if built-in losses are recognized. For instance, if a member comes into a group with a NUBIL and without an ownership change, recognition of that NUBIL would be subject to a SRLY limitation during the following five years and the loss could not be freely absorbed by the income of the other members of the group. However, if all the members of the group were included in a NUBIL subgroup upon being acquired by a second group two years into that five-year period,

that member's recognized built-in losses immediately thereafter would be subject either to a SRLY or section 382 limitation computed with respect to all the members of the former group (thus increasing the rate at which such losses can be utilized) or, in the event that the acquired corporations have an aggregate NUBIG, to no limitation whatsoever.

Some commentators contended that the five-year affiliation requirement (and the time period required for a fold-in event under §1.1502-96(a)) should be reduced to three years, based on the duration of the testing period for an ownership change under section 382.

However, a five-year (rather than a three-year) affiliation requirement is necessary to ensure that taxpayers cannot shorten the five-year recognition period for the SRLY limitation, as described above. Also, the IRS and Treasury believe that the five-year recognition period for the SRLY limitation should be maintained because it mirrors the statutorily-mandated five-year recognition period of section 382(h)(7). In general, Treasury and the IRS believe that it is important to conform the application of section 382 and the SRLY rules where possible, particularly in the light of the rule eliminating application of SRLY where its application overlaps with that of section 382.

Moreover, the five-year affiliation requirement is consistent with Congress' indication in section 384(a) of the point at which it is appropriate for built-in attributes of a member to be treated as attributes of the group. Under certain circumstances, section 384(a) prevents the recognized built-in gain of one corporation from offsetting preacquisition losses of another corporation, if such gain is recognized within a five-year period following the acquisition date. Similarly, section 384(b) provides that section 384(a) does not apply to prevent the recognized built-in gain of one corporation from offsetting the preacquisition losses of another corporation if the gain corporation and the loss corporation were members of the same controlled group (as defined in section 384(b)(2)) for the five-year period ending on the acquisition date.

For these reasons, the final regulations do not reduce the duration of the affiliation requirement from five years to three years.

Commentators requested clarification that an acquiring group takes into account application of the fold-in rules of §1.1502-96(a) in the former group in determining which members are included in a loss subgroup. A new example under §1.1502-96(a)(3), and a cross-reference in a new §1.1502-91(g)(3) to the fold-in rules, clarifies this treatment. Thus, a corporation whose NUBIL folded in to a former group is deemed to have a five-year affiliation with the common parent of that group (and is deemed to have affiliation histories with other group members). A special rule provides that the corporation is not deemed to have been previously affiliated with another corporation that joined the former group at the same time, but was not taken into account in determining a NUBIL limitation, even if in fact the two corporations were previously affiliated.

3. Members Included—Determination Whether a Consolidated Group Has a NUBIL, §1.1502-91(g)(2)(ii)

Proposed §1.1502-91(g)(2)(i) provides, in part, that the members included in the determination whether a consolidated group has a NUBIG or NUBIL are all members of the group on the day the determination is made, other than a new loss member with a NUBIL, and members included in a NUBIL subgroup.

The IRS and Treasury have determined that the reasons for applying a five-year affiliation requirement to subgroups are equally relevant to groups. Accordingly, these final regulations provide that the members included in the determination whether a consolidated group has a NUBIL are the common parent and all other members that have been affiliated with the common parent for the five consecutive year period ending on the day that the determination is made.

In certain cases, a member (or loss subgroup) can join a consolidated group with a NUBIG, but have a NUBIL on the date the consolidated group determines whether it has a NUBIL. The IRS and Treasury have determined that, in such cases, it is appropriate for the built-in attribute of the member to be included in the group's determination because it is clear that such NUBIL arose when it was a group member. Accordingly, the final

regulations include in the determination whether a group has a NUBIL any member that has a NUBIL on the date the determination is made, and that is neither a new loss member with a NUBIL nor a member of a NUBIL loss subgroup. The final regulations also include members in the group's determination whether the group has a NUBIL if such member(s) joined the consolidated group with a NUBIL, and, in the aggregate, have a NUBIG on the day that such determination is made.

4. Included—Determination Whether a Consolidated Group (or Loss Subgroup) with a Net Operating Loss Has a NUBIG, §1.1502-91(g)(2)(i)

Proposed §1.1502-93(c) provides that if a loss group (or loss subgroup) has a NUBIG, *any* recognized built-in gain of the loss group (or loss subgroup) is taken into account under section 382(h) in determining the consolidated section 382 limitation (or subgroup section 382 limitation)(emphasis added).

Commentators suggested that this provision, considered together with the five-year affiliation requirement, makes it unclear whether an NOL loss subgroup with members that do not satisfy the five-year affiliation requirement can use a NUBIG, if recognized, to increase the loss subgroup's section 382 limitation.

The IRS and Treasury have determined that the concerns forming the basis of the five-year affiliation requirement for determining whether a loss subgroup has a NUBIL do not extend to the determination whether a net operating loss carry-over group (or loss subgroup) has a NUBIG. For example, unlike a NUBIL that can be eliminated by a NUBIG without an immediate tax cost, recognized built-in gains exact such a cost and, therefore, do not present the same planning opportunities. Accordingly, these final regulations provide that the members included in the determination whether an NOL loss group (or loss subgroup) has a NUBIG are all members of the group (or loss subgroup) on the day that the determination is made.

Section 1.1502-91(g)(2)(v) provides, in part, that in determining whether an NOL loss group has a NUBIG which, if recognized, increases the consolidated

section 382 limitation, the group includes all of its members on the day the determination is made. However, for purposes of determining whether a group has a net unrealized built-in loss, not all members of the consolidated group may be included. Thus, a consolidated group may have recognized built-in gains that increase the amount of consolidated taxable income that may be offset by its pre-change net operating loss carryovers that did not arise (and are not treated as arising) in a SRLY, and also may have recognized built-in losses the absorption of which is limited. Similar results may obtain for loss subgroups. In such cases, §1.1502-93(c)(2) prohibits the use of recognized built-in gains to increase the amount of consolidated taxable income that can be offset by recognized built-in losses.

5. Recognized Built-in Gain or Loss on the Disposition of an Intercompany Obligation of a Member, §1.1502-91(h)(2)

Proposed §1.1502-91(h)(2) provides that gain or loss recognized by a member on the disposition of stock of another member or of an intercompany obligation is treated as recognized built-in gain or loss under section 382(h)(2) (unless disallowed under §1.1502-20 or otherwise), even though gain or loss on such stock or obligation is not included in the determination of the group's NUBIG or NUBIL immediately before the ownership change. The IRS and Treasury have determined that such treatment may lead to inappropriate results. For instance, if a bad debt deduction is treated as a recognized built-in loss, application of a section 382 limitation to that loss may prevent the proper offset of cancellation of indebtedness income against the bad debt deduction. Accordingly, §1.1502-91(h)(2) of the final regulations treats gain or loss recognized on the disposition of an intercompany obligation as recognized built-in gain or loss only to the extent that the transaction gives rise to aggregate income or loss within the consolidated group.

6. Ownership Change Determination—The Parent Change Method, §1.1502-92

Proposed §1.1502-92 provides rules

for determining an ownership change of a loss group (or a loss subgroup). A loss group (or loss subgroup) has an ownership change only if the common parent has an ownership change under the parent change method. Out of concern that taxpayers could exploit the parent change method's failure to account for minority shifts of stock, the proposed regulations adopted a supplemental change method that does take into account minority shifts of stock under certain circumstances.

Under the proposed regulations, the supplemental method applies if a person who is a 5-percent shareholder of the common parent (including any person acting pursuant to a plan or arrangement with such 5-percent shareholder) increases its percentage ownership both in the common parent and in any subsidiary of the group within the same testing period. In that event, the loss group (or loss subgroup) must also determine whether it had an ownership change under the rules for the parent change method by treating the common parent as though it had issued to the person who acquires (or is deemed to acquire) the subsidiary stock an amount of its own stock (by value) that equals the value of the subsidiary stock represented by the percentage increase in that person's ownership of the subsidiary (determined on a separate entity basis).

Section 1.1502-92(c), *Example 2* of the proposed regulations illustrates application of the supplemental change method. In *Example 2*, A owns all the stock of L, a loss group parent, and L owns all of the stock of L1. As part of a plan, A sells 49 percent of the L stock to B on October 7, Year 2, and L1 issues new stock representing a 20 percent ownership interest in L1 to the public on November 6, Year 2. The example concludes that "because the issuance of L1 stock to the public occurs in connection with B's acquisition of L stock pursuant to a plan," the supplemental change method applies to the public offering of L1 stock.

Commentators suggest that the "plan or arrangement" language sweeps too broadly, and that only plans to avoid section 382 should be subject to this rule. Commentators also contend that *Example 2* is beyond the scope of the operative rule because the facts do not demonstrate a plan or arrangement with a 5-percent shareholder.

The IRS and Treasury believe that it is appropriate to apply the supplemental change method to certain acquisitions of a loss group in which the plan is not between the 5-percent shareholder of the loss group parent and another person to increase their interests in the loss group. For example, if an individual buys 50 percent or less of the stock of a loss group parent, and as part of the same plan, causes a public offering out of a subsidiary, the supplemental change method should apply to that offering. (Conversely, the supplemental change method should not apply unless the 5-percent shareholder's increase in the stock of parent or subsidiary is related to the increase by another person because those increases are pursuant to the same plan.)

Accordingly, these final regulations provide that a 5-percent shareholder of the common parent (or loss subgroup parent) is treated as increasing its ownership interest in the stock of a subsidiary to the extent, if any, that the percentage ownership interest of another person or persons in the stock of the subsidiary is increased pursuant to a plan or arrangement under which the 5-percent shareholder increases its percentage ownership interest in the common parent (or loss subgroup parent).

To alleviate concerns that the supplemental change method is overly broad, the final regulations limit the scope of the supplemental change method through application of the rules of §1.382-2T(k). The final regulations provide that the supplemental change method will apply if the common parent (or loss subgroup parent) has actual knowledge of the increase in the 5-percent shareholder's ownership interest in the stock of the subsidiary (or has actual knowledge of the plan or arrangement) before the date that the group's income tax return is filed for the taxable year that includes the date of that increase or, if, at any time during the testing period, the 5-percent shareholder of the common parent is also a 5-percent shareholder of the subsidiary (determined without regard to a deemed acquisition of subsidiary stock under the plan or arrangement rule) whose percentage increase in the ownership of the stock of the subsidiary would be taken into account in determining if the subsidiary has an ownership change. For purposes of determining the 5-percent shareholders of the sub-

subsidiary, the principles of §1.382-2T(k), including the duty to inquire, apply to the common parent (or loss subgroup parent).

Several additional changes to the supplemental change method were made in response to comments. Section 1.1502-92(c)(4)(iii) clarifies that stock treated as issued under the supplemental change method is not treated as issued in testing periods that do not include the testing date on which the parent stock is deemed to be issued. Section 1.1502-92(c)(4)(ii) provides that stock is not treated as issued if a deemed issuance of parent stock would not cause the loss group (or loss subgroup) to have an ownership change before the day on which the subsidiary leaves the loss group (or loss subgroup).

To avoid retroactive changes in ownership, §1.1502-92(c)(4)(v) provides that if the supplemental change method applies to an acquisition of subsidiary stock before the first date that the 5-percent shareholder increases its percentage ownership interest in the stock of the common parent (or loss subgroup parent), then the deemed issuance of stock is treated as occurring on the first such date. However, the value of the subsidiary stock is the value of such stock on the date it was acquired. In addition, §1.1502-92(c)(4)(vi) provides that if two or more 5-percent shareholders are treated as increasing their percentage ownership interests pursuant to a single plan or arrangement described above, appropriate adjustments must be made so that the amount of stock treated as issued is not taken into account more than one time.

Commentators also requested that the supplemental change method apply only if the acquisitions of parent stock and subsidiary stock are with a principal purpose of avoiding or lessening the impact of section 382. The IRS and Treasury believe that if the same 5-percent shareholder increases in the stock of both a subsidiary and the common parent within the same testing period, the supplemental change method should apply without further evidence of an avoidance purpose. Similarly, a plan or arrangement under which a 5-percent shareholder and another person both increase their interests in the loss group is sufficient proof of an avoidance purpose that the supplemental change method properly applies without further inquiry.

7. Consolidated Section 382 Limitation, §1.1502-93

Proposed §1.1502-93 provides rules for computing the consolidated section 382 limitation following an ownership change of a loss group. The value of the loss group is the value, immediately before the ownership change, of the stock (including stock described in section 1504(a)(4)) of each member of the loss group, other than stock that is owned directly or indirectly by a member. Section 1.1502-93(b)(2) provides that this value is adjusted under any rule in section 382 (such as section 382(l)(1), relating to certain capital contributions) requiring an adjustment to value for purposes of computing the section 382 limitation. The section 382 limitation, as so determined, is further adjusted as required by section 382 and the regulations thereunder (such as section 382(m)(2), relating to a short taxable year). Similar rules apply in determining the section 382 limitation for a loss subgroup.

In response to comments, the final regulations make several clarifications with respect to circumstances that require an adjustment to the value of a loss group or loss subgroup.

Section 1.1502-93(b)(2)(i) provides that, for purposes of section 382(e)(2), redemptions and corporate contractions that do not effect a transfer of value outside of the loss group (or loss subgroup) are disregarded. For purposes of section 382(l)(1), capital contributions between members of the loss group (or loss subgroup) (or a contribution of stock to a member made solely to satisfy the loss subgroup parent requirement of §§1.1502-91(d)(1)(ii) or 1.1502-91(d)(2)(ii)), are not taken into account. Also, the substantial nonbusiness asset test of section 382(l)(4) is applied on a group (or subgroup) basis, and is not applied separately to its members.

Section 1.1502-93(b)(2)(ii) provides rules that apply to prevent duplication of value of the group (or loss subgroup) and to prevent duplication of the section 382 limitation. This section provides that appropriate adjustments must be made to the extent necessary to prevent any duplication of the value of the stock of a member, even though corporations that do not file consolidated returns may not be required to make

such an adjustment. In making these adjustments, the group (or loss subgroup) may apply the principles of §1.382-8 (relating to controlled groups of corporations) in determining the value of a loss group (or loss subgroup) even if that section would not apply if separate returns were filed. Also, the principles of §1.382-5(d) (relating to successive ownership changes and absorption of a section 382 limitation) may apply to adjust the consolidated section 382 limitation (or subgroup section 382 limitation) of a loss group (or loss subgroup) to avoid a duplication of value if there are simultaneous (rather than successive) ownership changes.

One commentator suggested that contributions of assets by the selling group to a departing member or loss subgroup generally should not be subject to section 382(l)(1). The IRS and Treasury have determined that, unlike transfers of stock or assets that do not effect a transfer of value into a loss subgroup, capital contributions that constitute a transfer of value into a loss group or to a departing member should continue to be subject to section 382(l)(1).

A new §1.1502-93(c)(2) provides that appropriate adjustments must be made so that any recognized built-in gain of a member that increases more than one section 382 limitation (whether consolidated, subgroup, or separate) does not effect a duplication in the amount of consolidated taxable income that can be offset by pre-change net operating losses. In addition, recognized built-in gains may not increase the amount of consolidated taxable income that can be offset by recognized built-in losses.

8. Ceasing to Be a Member of a Consolidated Group (or Loss Subgroup), §1.1502-95

Elective apportionment of NUBIG

In general, the common parent of a consolidated group may elect to apportion all or part of each element (the value element and the adjustment element) of a consolidated section 382 limitation to a former member or loss subgroup. The proposed regulations do not provide that the common parent may elect to apportion all or part of a loss group's NUBIG.

Under section 382(h)(1)(A), if a consolidated group has a NUBIG immediately before an ownership change, the

section 382 limitation for any recognition period taxable year is increased by the recognized built-in gain for such taxable year. This increase cannot exceed the NUBIG, reduced by recognized built-in gains for prior years ending in the recognition period.

Commentators suggest that, like the value element and the adjustment element of the consolidated section 382 limitation, the common parent should be able to apportion any part or all of the group's NUBIG to a departing member (or loss subgroup). The final regulations adopt this recommendation.

In general, §1.1502-95(c)(2)(ii) provides that the amount of the loss group's NUBIG that may be apportioned to one or more former members that cease to be members during the same consolidated return year cannot exceed the loss group's excess, immediately after the close of that year, of net unrealized built-in gain over recognized built-in gain, determined under section 382(h)(1)(A)(ii) (relating to a limitation on recognized built-in gain). In general, NUBIG apportioned to a former member reduces the amount of NUBIG that the group can avail itself of in subsequent taxable years.

For purposes of determining the extent to which the former member's section 382 limitation can be increased by recognized built-in gains, the amount of NUBIG apportioned is treated as if it were an amount determined under section 382(h) with respect to the former member. The former member's five-year recognition period begins on the group's (or loss subgroup's) change date.

Default apportionment of zero section 382 limitation and NUBIG when a member ceases to be a member of a group (or loss subgroup), §1.1502-95(c)(2)(ii)

Section 1.1502-95(c)(1) provides that the common parent may elect to apportion all or any part of a consolidated section 382 limitation to a former member (or a loss subgroup) when the member or loss subgroup leaves the group. If the common parent does not make an apportionment of the applicable section 382 limitation(s) or of a NUBIG that the member recognizes during the recognition period, the former member or loss subgroup has a

consolidated section 382 limitation of zero with respect to pre-change attributes (the zero default rule).

Commentators suggested that the zero default rule may be a trap for the unwary. For instance, under the proposed regulations, a subgroup member that ceases to bear a section 1504(a)(1) to the subgroup parent is subject to the zero default rule, even if that member remains within the current consolidated group.

The IRS and Treasury recognize that any default rule will benefit some taxpayers while operating to the detriment of others. For example, a default apportionment of a section 382 limitation or NUBIG based on the departing member's contribution to the group's net operating loss carryover could cause some apportioned limitation to go unused if that member becomes subject to a new section 382 limitation upon departing the group. By contrast, a rule providing that the default limitation is capped by the amount of any subsequent section 382 limitation, would be difficult to administer. Because the consequences of applying any default rule depend on the particular facts of a transaction, including the relative income generation of the departing and remaining members, the IRS and Treasury believe that the simplicity of the zero default rule makes the rule preferable to other alternatives.

Also, the IRS and the Treasury believe that the new exceptions to ceasing to be a member of a loss subgroup substantially reduce the likelihood that the zero default rule will yield unexpected results. For example, an acquisition of a loss subgroup typically will cause an ownership change of the loss subgroup. Following that ownership change, a member that remains within the current group now can break the section 1504(a)(1) relationship to the loss subgroup parent without ceasing to be a member of the loss subgroup. Accordingly, these final regulations retain the zero default rule when a member ceases to be a member of a group (or loss subgroup). The zero default rule also applies to a NUBIG.

Mandatory apportionment of a group's NUBIG to a departing member, §1.1502-95(e)

In general, a group has a NUBIG if the adjusted bases of the assets of members

included in such determination under §1.1502-91(g) exceed their fair market value immediately before the change date. Similar rules apply to loss subgroups. Subject to the limitations of section 382(h)(2)(B), NUBIGs recognized within the five year period beginning on the change date are subject to the consolidated section 382 limitation. The proposed regulations do not provide rules for apportioning a group's NUBIG to a former member (or loss subgroup). The IRS and Treasury believe that a mandatory apportionment of the group's NUBIG is necessary to ensure that the group's NUBIG, if recognized by the former member (or loss subgroup) during the recognition period, remains subject to the consolidated section 382 limitation. One commentator suggests that a former member (or loss group) should be apportioned a group's NUBIG only if and when a former member that had a separately computed NUBIG that contributed to the group's NUBIG departs the group, and the contributed built-in loss has not fully been recognized. Adjustments would reflect intragroup transfers of assets occurring between the change date and the date that the former member departs.

The IRS and Treasury believe that the suggested approach overemphasizes the location of assets with a NUBIG. For example, if a former member has a NUBIG determined on a separate entity basis, a recognized built-in loss of that member will not be limited, even if the former member is the first corporation to dispose of a built-in loss asset. The IRS and Treasury believe that subjecting the sale of built-in loss assets to the consolidated section 382 limitation, regardless of the location of built-in gain assets, more accurately reflects the NUBIG as a group attribute. Similarly, consistent with treatment of the NUBIG as a group attribute, the approach permits built-in gain to be sheltered by built-in loss only after the excess of built-in losses over built-in gains has been recognized. Accordingly, these final regulations adopt a model that apportions NUBIG based on the gross amount of built-in loss that the departing member contributed to the determination of the group's NUBIG.

In general, §1.1502-95(f) provides that a departing member is allocated a portion of the group's (or loss subgroup's)

NUBIL if, immediately after the close of the consolidated return year in which the departing member ceases to be a member, the amount of the loss group's (or loss subgroup's) excess of net unrealized built-in loss over recognized built-in loss (the remaining NUBIL balance) is greater than zero. In general, NUBIL apportioned to former members in prior taxable years is treated as recognized built-in loss in those years.

The amount of NUBIL allocated to a departing member is equal to the remaining NUBIL balance multiplied by a fraction. The numerator of the fraction is the amount of the built-in loss, taken into account on the change date, in the assets held by the departing member immediately after the member ceases to be a member of the loss group (or loss subgroup). The denominator of the fraction is the sum of the numerator, plus the amount of the built-in loss, taken into account on the change date, in the assets held by the group immediately after the close of the taxable year in which the departing member ceases to be a member. (Fluctuations in value of the assets between the change date and the date that the member ceases to be a member of the group (or loss subgroup), or the close of the taxable year in which the member ceases to be a member of the loss group, are disregarded.) In general, adjustments are made for gain or loss that has been recognized during the recognition period, and for assets that are transferred basis property. The amount of the NUBIL allocated to a former member generally is treated as previously recognized built-in loss for purposes of applying the limitation of section 382(h)(1)(B)(ii) to a loss group's taxable years beginning after the year in which the former member ceases to be a member.

For purposes of determining the amount of the former member's recognized built-in losses in any taxable year beginning after the former member ceases to be a member, the amount of the loss group's (or loss subgroup's) net unrealized built-in loss that is apportioned to the former member is treated as if it were an amount of net unrealized built-in loss determined under section 382(h)(1)(B)(i) with respect to such member, and that amount is not reduced under section 382(h)(1)(B)(ii) by the loss group's (or

loss subgroup's) recognized built-in losses.

Subgroup principles apply to the allocation of a NUBIL. For example, if two or more members leave a loss group, and are members of a consolidated group, any allocation of the loss group's NUBIL is made on a subgroup basis. In general, the common parent may apportion all or any part of a consolidated section 382 limitation (or subgroup section 382 limitation) under §1.1502-95(c) to a former member to which the group's NUBIL is allocated (or to a loss subgroup that includes that member).

9. Miscellaneous Rules, §1.1502-96

Fold-in rules do not apply to NUBIGs, §1.1502-96(a)

Proposed §1.1502-96(a)(2) provides in part that, following a fold-in event described in §1.1502-96(a)(1), the member's separately computed NUBIG or NUBIL is included in the determination whether the group has a NUBIG or NUBIL.

The IRS and Treasury believe that the "fold-in" of a member's NUBIG can lead to inappropriate results. For example, a consolidated group that acquires a corporation with a small net operating loss carryover and a large NUBIG can immediately offset the group's NUBIL with the NUBIG, if the member is acquired with an ownership change. Accordingly, the fold-in rules of §1.1502-96(a) do not apply to include a member's separately computed NUBIG in determining whether a group has a NUBIL. A member's NUBIG is only included in such determination if the member is included under §1.1502-91(g)(2).

Net operating loss carryovers reattributed under §1.1502-20(g)

Section 1.1502-20 of the regulations disallows a deduction for certain losses on the disposition of stock of a subsidiary. In general, under §1.1502-20(g), the common parent can reattribute to itself net operating loss carryovers or capital loss carryovers attributable to the subsidiary in an amount not to exceed the disallowed loss. Section 1.1502-20(g) further provides that the common parent succeeds to the reattributed losses as if the losses were suc-

ceeded to in a transaction described in section 381(a). Also, any owner shift of the subsidiary (including any deemed owner shift resulting from section 382(g)(4)(D) or 382(l)(3)) in connection with the disposition is not taken into account under section 382 with respect to the reattributed losses. (§1.1502-20(g)(1)). The preamble to T.D. 8364 (56 F.R. 47379, September 19, 1991)(which added §1.1502-20), states that clarification regarding the application of section 382 to reattributed losses would be provided in connection with finalizing §§1.1502-91 through 1.1502-99. The preamble states that, for example, it is anticipated that proposed §1.1502-95 would be modified to permit the common parent to elect to retain all or part of a section 382 limitation that applies to reattributed SRLY losses.

A new §1.1502-96(d) provides rules relating to reattributed losses. This section generally provides that §§1.1502-91 through 1.1502-96 and §1.1502-98 apply to reattributed losses consistent with the provision of §1.1502-20(g) that treats the common parent as succeeding to the losses in a transaction to which section 381(a) applies. For example, if the reattributed loss is a pre-change attribute subject to a section 382 limitation, it remains subject to that limitation following the reattribution. Section 1.1502-96(d)(4) provides rules that allow the common parent to elect to apportion to itself all or part of any separate section 382 limitation or subgroup section 382 limitation to which the reattributed loss is subject. The apportionment is made under the principles of the rules of §1.1502-95(c), relating to the apportionment of a consolidated section 382 limitation to a member that leaves the group. In certain cases, the section 382 limitation applicable to the reattributed loss is zero unless an apportionment of such limitation is made to the common parent. The election to apportion a section 382 limitation is made as part of the election to reapportion the loss. See §1.1502-20(g)(4), as amended by this document.

As previously set forth in §1.1502-20(g), §1.1502-96(d) adopts the general rule that any owner shift of the subsidiary (including any deemed owner shift resulting from section 382(g)(4)(D) or 382(l)(3)) in connection with the disposition of the subsidiary's stock) is not taken

into account under section 382 with respect to the reattributed losses. The final regulations, however, modify the general rule to provide that any owner shift with respect to the successor corporation that is treated as continuing in existence under §1.382-2(a)(1)(ii) must be taken into account for such purpose if such owner shift is effected by the reattribution and any owner shift of the stock of the subsidiary not held directly or indirectly by the common parent would have been taken into account if such shift had occurred immediately before the reattribution. Such an owner shift may occur if the subsidiary has minority shareholders that, under §1.382-2(a)(1)(ii), are treated as decreasing their ownership in the reattributed loss, while the shareholders of the common parent increase their ownership interests in that loss.

The final regulations provide that, in general, the value of the stock of the common parent is used to establish a section 382 limitation for the reattributed loss with respect to an ownership change upon, or after, the reattribution. These rules coordinate the determination of the value of that stock with the capital contribution rules of section 382(l)(1), and also require appropriate adjustments so that value is not improperly omitted or duplicated as a result of the reattribution.

Effective Dates

Sections 1.1502-91 through 1.1502-96 and 1.1502-98

Except as set forth below, §§1.1502-91 through 1.1502-96 and 1.1502-98 apply to testing dates that occur on or after June 25, 1999. Sections 1.1502-94 through 1.1502-96 also apply on any date on or after June 25, 1999 on which a corporation becomes a member of a group or on which a corporation ceases to be a member of a loss group (or a loss subgroup).

A transition rule for net unrealized built-in loss provides that a consolidated group may apply §1.1502-91A(g) for the period ending on the day before June 25, 1999 to determine the earliest date that its testing period begins (treating the day before June 25, 1999 as the end of a taxable year.)

The election under §1.1502-91(d)(4) to treat the subgroup parent requirement as satisfied is effective for corporations that become members of a consolidated group

in taxable years for which the due date of the income tax return (without extensions) is after June 25, 1999. Section 1.1502-95(d)(2)(ii) (relating to exceptions to ceasing to be a member of loss subgroup) applies to corporations that cease to bear a section 1504(a)(1) relationship to a loss subgroup parent in taxable years for which the due date of the income tax return (without extensions) is after June 25, 1999.

The third sentence of §1.1502-91(d)-(5) (relating to members excluded from a loss subgroup) applies to corporations that become members of a consolidated group on or after June 25, 1999.

In the case of corporations that cease to be members of a loss group (or loss subgroup) before June 25, 1999, in a taxable year for which the due date of the income tax return (without extensions) is after June 25, 1999, §§1.1502-95(a), (b), (c) and (f) apply to those corporations if the common parent makes the election described in the second sentence of (c)(1) of that section in the time and manner prescribed in paragraph (f) of that section.

Section 1.1502-96(d) applies to reattributions of net operating losses or net capital losses in taxable years for which the due date of the income tax return (without extensions) is after June 25, 1999; except that the election under §1.1502-96(d)(5) (relating to an election to reattribute section 382 limitation) can be made with any election under §1.1502-20(g)(4) to reattribute to the common parent a net operating loss or net capital loss that is timely filed on or after June 25, 1999.

Sections 1.1502-91A through 1.1502-96A and 1.1502-98A apply to any testing date on or after January 1, 1997, and before June 25, 1999. Sections 1.1502-94A through 1.1502-96A also apply on any date on or after January 1, 1997, and before June 25, 1999, on which a corporation becomes a member of a group or on which a corporation ceases to be a member of a loss group (or a loss subgroup). For periods before January 1, 1997, the transition rules in §1.1502-99A(c) continue to apply.

The transition rules in §1.1502-99A for periods ending before January 1, 1997 also are clarified to provide that a member that ceases to be a member of a group does not have a zero section 382 limitation with respect to pre-change net operat-

ing losses allocated to that member.

Need For Immediate Guidance

Because the temporary regulations are not applicable for taxable years ending after June 26, 1999, it is necessary to implement these final regulations without delay to ensure continuity of treatment of certain attributes and to ensure that there is no period within which the treatment of such attributes is inconsistent with the temporary regulations and these final regulations. See section 7805(e)(2). Accordingly, it is impracticable and contrary to the public interest to issue this Treasury decision subject to the effective date limitation of section 553(d) of title 5 of the United States Code (if applicable).

SPECIAL ANALYSIS

It has been determined that this Treasury decision is not a significant regulatory action as defined in EO 12866. It is hereby certified that these regulations do not have a significant economic impact on a substantial number of small entities. This certification is based on the fact that these regulations principally affect corporations filing consolidated federal income tax returns that have net operating losses or other attributes that are subject to section 382. Available data indicates that many consolidated return filers are large companies (not small businesses). In addition, the data indicates that an insubstantial number of consolidated return filers that are smaller companies have net operating losses or other attributes subject to section 382. Moreover, many of these corporations will not have ownership changes. Therefore, a Regulatory Flexibility Analysis under the Regulatory Flexibility Act (5 U.S.C. chapter 6) is not required. Pursuant to section 7805(f) of the Internal Revenue Code, the notice of proposed rulemaking preceding these regulations was sent to the Small Business Administration for comment on its impact on small business.

DRAFTING INFORMATION

The principal author of the final regulations is Lee A. Kelley of the Office of Assistant Chief Counsel (Corporate), IRS. Other personnel from the IRS and Treasury participated in their development.

Adoption of Amendments to the Regulations

Accordingly, 26 CFR parts 1 and 602 are amended as follows:

PART 1—INCOME TAXES

Paragraph 1. The authority citation for part 1 is amended by removing the entries for sections 1.1502–91T, 1.1502–92T, 1.1502–93T, 1.1502–94T, 1.1502–95T, 1.1502–96T, 1.1502–98T, and 1.1502–99T, and adding entries in numerical order to read in part as follows:

Authority: 26 U.S.C. 7805 * * *

Section 1.1502–91 also issued under 26 U.S.C. 382(m) and 26 U.S.C. 1502.

Section 1.1502–92 also issued under 26 U.S.C. 382(m) and 26 U.S.C. 1502.

Section 1.1502–93 also issued under 26 U.S.C. 382(m) and 26 U.S.C. 1502.

Section 1.1502–94 also issued under 26 U.S.C. 382(m) and 26 U.S.C. 1502.

Section 1.1502–95 also issued under 26 U.S.C. 382(m) and 26 U.S.C. 1502.

Section 1.1502–96 also issued under 26 U.S.C. 382(m) and 26 U.S.C. 1502.

Section 1.1502–98 also issued under 26 U.S.C. 382(m) and 26 U.S.C. 1502.

Section 1.1502–99 also issued under 26 U.S.C. 382(m) and 26 U.S.C. 1502. * * *

Section 1.1502–91A also issued under 26 U.S.C. 382(m) and 26 U.S.C. 1502.

Section 1.1502–92A also issued under 26 U.S.C. 382(m) and 26 U.S.C. 1502.

Section 1.1502–93A also issued under 26 U.S.C. 382(m) and 26 U.S.C. 1502.

Section 1.1502–94A also issued under 26 U.S.C. 382(m) and 26 U.S.C. 1502.

Section 1.1502–95A also issued under 26 U.S.C. 382(m) and 26 U.S.C. 1502.

Section 1.1502–96A also issued under 26 U.S.C. 382(m) and 26 U.S.C. 1502.

Section 1.1502–98A also issued under 26 U.S.C. 382(m) and 26 U.S.C. 1502.

Section 1.1502–99A also issued under 26 U.S.C. 382(m) and 26 U.S.C. 1502. * * *

Par. 2. In the list below, for each section indicated in the left column, remove the wording indicated in the middle column, and add the wording indicated in the right column.

<i>Affected Section</i>	<i>Remove</i>	<i>Add</i>
1.1502–91T(a)(1), first sentence	§§ 1.1502–92T and 1.1502–93T	§§ 1.1502–92A and 1.1502–93A
1.1502–91T(a)(1), third sentence	§ 1.1502–92T	§ 1.1502–92A
1.1502–91T(a)(1), third sentence	§ 1.1502–93T	§ 1.1502–93A
1.1502–91T(a)(3)	§§ 1.1502–94T and 1.1502–95T	§§ 1.1502–94A and 1.1502–95A
1.1502–91T(b) introductory text	§§ 1.1502–92T through 1.1502–99T	§§ 1.1502–92A through 1.1502–99A
1.1502–91T(b)(1)	§§ 1.1502–92T through 1.1502–99T	§§ 1.1502–92A through 1.1502–99A
1.1502–91T(c)(2), second sentence	§ 1.1502–96T(a)	§ 1.1502–96A(a)
1.1502–91T(c)(3), Example(b), second sentence	§ 1.1502–94T	§ 1.1502–94A
1.1502–91T(d)(4), second sentence	§ 1.1502–94T	§ 1.1502–94A
1.1502–91T(d)(5), first sentence	§ 1.1502–95T(d)	§ 1.1502–95A(d)
1.1502–91T(d)(5), second sentence	§ 1.1502–96T(a)	§ 1.1502–96A(a)
1.1502–91T(e)(2), Example(b), third sentence	§ 1.1502–93T	§ 1.1502–93A
1.1502–91T(f)(2), Example(b)(2), first sentence	§ 1.1502–96T(a)	§ 1.1502–96A(a)
1.1502–91T(f)(2), Example(b)(2), third sentence	§ 1.1502–92T(a)(2)	§ 1.1502–92A(a)(2)
1.1502–91T(f)(2), Example(b)(2), fourth sentence	§ 1.1502–93T	§ 1.1502–93A
1.1502–91T(f)(2), Example(c), second sentence	§ 1.1502–96T(c)	§ 1.1502–96A(c)
1.1502–91T(g)(1), last sentence	§ 1.1502–94T(c)	§ 1.1502–94A(c)
1.1502–91T(g)(1), last sentence	§ 1.1502–96T(a)	§ 1.1502–96A(a)
1.1502–91T(g)(2)(i)(A)	§ 1.1502–94T(a)(1)(ii)	§ 1.1502–94A(a)(1)(ii)
1.1502–91T(g)(2)(i)(B)	§ 1.1502–91T(d)(2)	§ 1.1502–91A(d)(2)
1.1502–91T(j), first sentence	§§ 1.1502–92T through 1.1502–99T	§§ 1.1502–92A through 1.1502–99A

1.1502–92T(a), second sentence	§ 1.1502–94T	§ 1.1502–94A
1.1502–92T(a), second sentence	§1.1502–96T(b)	§ 1.1502–96A(b)
1.1502–92T(b)(1)(i)(A)	§ 1.1502–91T(c)	§ 1.1502–91A(c)
1.1502–92T(b)(1)(i)(B)	§ 1.1502–91T(c)	§ 1.1502–91A(c)
1.1502–92T(b)(1)(ii), second sentence	§ 1.1502–95T(b)	§ 1.1502–95A(b)
1.1502–92T(b)(1)(ii)(A)	§ 1.1502–91T(d)	§ 1.1502–91A(d)
1.1502–92T(b)(1)(ii)(C)	§ 1.1502–91T(d)	§ 1.1502–91A(d)
1.1502–92T(b)(2) Example 1(a), sixth sentence	§ 1.1502–91T(c)(1)	§ 1.1502–91A(c)(1)
1.1502–92T(b)(2) Example 3(b), first sentence	§ 1.1502–91T(d)(1)	§ 1.1502–91A(d)(1)
1.1502–92T(b)(2) Example 4(b), first sentence	§ 1.1502–91T(d)(1)	§ 1.1502–91A(d)(1)
1.1502–92T(b)(3)(iii) Example 2(d), fourth sentence	§ 1.1502–94T	§ 1.1502–94A
1.1502–92T(b)(3)(iii) Example 3(a), seventh sentence	§ 1.1502–91T(d)	§ 1.1502–91A(d)
1.1502–92T(b)(4), first sentence	§ 1.1502–96T(a)	§ 1.1502–96A(a)
1.1502–92T(b)(4), first sentence	§ 1.1502–96T(a)(2)	§ 1.1502–96A(a)(2)
1.1502–92T(b)(4), first sentence	§ 1.1502–96T(b)	§ 1.1502–96A(b)
1.1502–92T(b)(4), second sentence	§ 1.1502–96T(a) applies, see § 1.1502–96T(c)	§1.1502–96A(a) applies, see § 1.1502–96A(c)
1.1502–92T(e)(1)(ii)	§ 1.1502–96T(b)	§ 1.1502–96A(b)
1.1502–92T(e)(2), fifth sentence	§ 1.1502–96T(a)	§ 1.1502–96A(a)
1.1502–92T(e)(2), fifth sentence	§ 1.1502–91T(d)	§ 1.1502–91A(d)
1.1502–93T(a)(2)	§ 1.1502–95T(c)	§ 1.1502–95A(c)
1.1502–93T(b)(2), last sentence	§ 1.382–8T	§ 1.382–8
1.1502–93T(b)(2), fourth sentence	§ 1.1502–91T(g)(2)	§ 1.1502–91A(g)(2)
1.1502–94T(a)(1)(i)	§ 1.1502–91T(d)(1)	§ 1.1502–91A(d)(1)
1.1502–94T(a)(1)(ii)	§ 1.1502–91T(d)(2)	§ 1.1502–91A(d)(2)
1.1502–94T(a)(3)	§ 1.1502–91T(d)	§ 1.1502–91A(d)
1.1502–94T(a)(3)	§§ 1.1502–92T and 1.1502–93T	§§ 1.1502–92A and 1.1502–93A
1.1502–94T(a)(4), first sentence	§ 1.1502–96T(a)	§ 1.1502–96A(a)
1.1502–94T(a)(4), first sentence	§, 1.1502–96T(a)(2)	§1.1502–96A(a)(2)
1.1502–94T(a)(4), first sentence	§ 1.1502–92T(b)(1)(i)	§1.1502–92A(b)(1)(i)
1.1502–94T(a)(4), first sentence	§1.1502–96T(b)	§§1.1502–96A(b)
1.1502–94T(a)(4), second sentence	§ 1.1502–96T(a) applies, see § 1.1502–96T(c)	§ 1.1502–96A(a) applies, see § 1.1502–96A(c)
1.1502–94T(a)(5)	§ 1.1502–96T(c)	§ 1.1502–96A(c)
1.1502–94T(b)(4) Example 1(b), first sentence	§ 1.1502–91T(d)	§ 1.1502–91A(d)

1.1502–94T(b)(4) Example 2(b),	§ 1.1502–91T(d)(1)	§ 1.1502–91A(d)(1)
1.1502–94T(b)(4) Example 2(d), first sentence	§ 1.1502–96T(a)	§ 1.1502–96A(a)
1.1502–94T(b)(4) Example 2(d), third sentence	§ 1.1502–91T(c)	§ 1.1502–91A(c)
1.1502–94T(b)(4) Example 3(b), first sentence	§ 1.1502–91T(d)(1)	§ 1.1502–91A(d)(1)
1.1502–94T(b)(4) Example 3(c), second sentence	§§ 1.1502–96T(a) and 1.1502–91T(c)(2)	§§ 1.1502–96A(a) and 1.1502–91A(c)(2)
1.1502–94T(c), first sentence	§§ 1.1502–91T(g) and (h)	§§ 1.1502–91A(g) and (h) and 1.1502– 93A(c)
1.1502–94T(c), second sentence	§ 1.1502–91T(g)(3)	§ 1.1502–91A(g)(3)
1.1502–94T(d), fifth sentence	§ 1.1502–96T(a)	§ 1.1502–96A(a)
1.1502–94T(d), sixth sentence	§ 1.1502–92T(e)(1)	§ 1.1502–92A(e)(1)
1.1502–95T(a)(3), paragraph heading	§§ <i>1.1502–91T through 1.1502–93T</i>	§§ <i>1.1502–91A through 1.1502–93A</i>
1.1502–95T(a)(3)	§§ 1.1502–91T through 1.1502–93T	§§ 1.1502–91A through 1.1502–93A
1.1502–95T(b)(1) introductory text, first sentence	§§ 1.1502–91T through 1.1502–93T	§§ 1.1502–91A through 1.1502–93A
1.1502–95T(b)(2) introductory text	§ 1.1502–92T	§ 1.1502–92A
1.1502–95T(b)(4) Example(2)(a), second sentence	§ 1.1502–92T	§ 1.1502–92A
1.1502–95T(c)(2) introductory text	§ 1.1502–93T	§ 1.1502–93A
1.1502–95T(c)(7) Example(1)(a), third sentence	§ 1.1502–92T	§ 1.1502–92A
1.1502–95T(d)(2) Example(1)(a), fifth sentence	§ 1.1502–92T	§ 1.1502–92A
1.1502–95T(d)(2) Example(3)(a), fourth sentence	§ 1.1502–92T(b)(1)(ii)	§ 1.1502– 92A(b)(1)(ii)
1.1502–95T(e)(1) introductory text	§ 1.1502–95T	§ 1.1502–95A
1.1502–96T(a)(2) introductory text, first sentence	§ 1.1502–91T(c)(1)(i)	§ 1.1502–91A(c)(1)(i)
1.1502–96T(a)(2)(ii)	§ 1.1502–91T(c)	§ 1.1502–91A(c)
1.1502–96T(a)(3), second sentence	§ 1.1502–91T(f)(2)	§ 1.1502–91A(f)(2)
1.1502–96T(a)(5), first sentence	§§ 1.1502–91T through 1.1502–95T	§§ 1.1502–91A through 1.1502–95A
1.1502–96T(a)(5) introductory text, first sentence	§ 1.1502–98T	§ 1.1502–98A
1.1502–96T(b)(1) introductory text, first sentence	§ 1.1502–92T	§ 1.1502–92A
1.1502–96T(b)(1) introductory text, first sentence	§ 1.1502–91T(c)(1)	§ 1.1502–91A(c)(1)
1.1502–96T(b)(1) introductory text, first sentence	§ 1.1502–91T(d)	§ 1.1502–91A(d)
1.1502–96T(b)(1) introductory text, second sentence	§ 1.1502–95T(b)	§ 1.1502–95A(b)

1.1502-96T(b)(3), paragraph heading	§§ 1.1502-91T, 1.1502-92T, and 1.1502-94T	§§ 1.1502-91A, 1.1502-92A, and 1.1502-94A
1.1502-96T(b)(3), first sentence	§ 1.1502-92T	§ 1.1502-92A
1.1502-96T(b)(3), first sentence	§ 1.1502-92T	§ 1.1502-92A
1.1502-96T(b)(3), second sentence	§ 1.1502-94T	§ 1.1502-94A
1.1502-96(c), last sentence	§ 1.382-5T(d)	§ 1.382-5(d)
1.1502-98T, first sentence	§§ 1.1502-91T through 1.1502-96T	§§ 1.1502-91A through 1.1502-96A
1.1502-98T, second sentence	§§ 1.1502-91T through 1.1502-96T	§§ 1.1502-91A through 1.1502-96A
1.1502-98T, third sentence	§ 1.1502-92T	§ 1.1502-92A
1.1502-98T, third sentence	§ 1.1502-93T	§ 1.1502-93A
1.1502-99T(a), first sentence	Sections 1.1502-91T through 1.1502-96T and 1.1502-98T	Sections 1.1502-91A through 1.1502-96A and 1.1502-98A
1.1502-99T(a), second sentence	Sections 1.1502-94T through 1.1502-96T	Sections 1.1502-94A through 1.1502-96A
1.1502-99T(b), first sentence	§§ 1.1502-91T through 1.1502-96T and 1.1502-98T	§§ 1.1502-91A through 1.1502-96A and 1.1502-98A
1.1502-99T(b), second sentence	§ 1.1502-92T(b)(1)(i)	§ 1.1502-92A(b)(1)(i)
1.1502-99T(b), third sentence	§ 1.1502-92T(b)(1)	§ 1.1502-92A(b)(1)
1.1502-99T(c)(1)(ii)	§§ 1.1502-91T through 1.1502-96T and 1.1502-98T	§§ 1.1502-91A through 1.1502-96A and 1.1502-98A
1.1502-99T(c)(1)(iii), first sentence	§§ 1.1502-91T through 1.1502-96T and 1.1502-98T	§§ 1.1502-91A through 1.1502-96A and 1.1502-98A
1.1502-99T(c)(1)(iii), second sentence	§ 1.1502-92T	§ 1.1502-92A
1.1502-99T(c)(2)(i), first sentence	§§ 1.1502-91T through 1.1502-96T and 1.1502-98T	§§ 1.1502-91A through 1.1502-96A and 1.1502-98A
1.1502-99T(c)(2)(i), first sentence	§ 1.1502-95T(c)	§ 1.1502-95A(c)
1.1502-99T(c)(2)(i), fifth sentence	§ 1.1502-91T(d)(2)(i)	§ 1.1502-91A(d)(2)(i)
1.1502-99T(c)(2)(ii)	§ 1.382-8T	§ 1.382-8
1.1502-99T(c)(2)(ii)	§ 1.382-8T(h)	§ 1.382-8(h)
1.1502-99T(d)(1)	§ 1.1502-92T	§ 1.1502-92A
1.1502-99T(d)(3)	§§ 1.1502-91T through 1.1502-96T and 1.1502-98T	§§ 1.1502-91A through 1.1502-96A and 1.1502-98A

Par. 3. Section 1.1502-20 is amended as follows:

1. Adding a sentence to the end of paragraph (g)(1).

2. Redesignating paragraph (g)(5) as paragraph (g)(4).

3. Paragraph (g)(4)(i)(A) is amended by removing “, and” and adding “;” in its place.

4. Paragraph (g)(4)(i)(B) is amended by removing the period at the end of the paragraph and adding “; and” in its place.

5. Adding a new paragraph (g)(4)(i)(C) immediately after paragraph (g)(4)(i)(B) and before paragraph (g)(4)(i) concluding text.

6. Redesignating paragraph (g)(4)(ii) as paragraph (g)(4)(iii).

7. Adding a new paragraph (g)(4)(ii).

The revisions and additions read as follows:

§1.1502-20 Disposition or deconsolidation of subsidiary stock.

* * * * *

(g) * * *

(1) * * * See §1.1502-96(d) for rules relating to section 382 and the reattribution of losses under this paragraph (g).

* * * * *

(4)

(i) * * *

(C) If the common parent is reattributing to itself all or any part of a section 382 limitation pursuant to §1.1502-96(d)(5), the information required by paragraph (g)(4)(ii) of this section.

* * * * *

(ii) *Reattribution of section 382 limitation.* The information required by this paragraph (g)(4)(ii) is a separate list for each subsidiary (or a separate list for two or more subsidiaries that are members of a loss subgroup whose pre-change sub-

group losses are being reattributed) with respect to which an apportionment of a separate section 382 limitation or subgroup section 382 limitation is being made, setting forth—

(A) The name and E.I.N. of the subsidiary (or subsidiaries that were members of a loss subgroup);

(B) A statement entitled “THIS IS AN ELECTION UNDER §1.1502–96(d)(5) TO APPORTION ALL OR PART OF [insert A SEPARATE or A SUBGROUP or BOTH A SEPARATE AND A SUBGROUP] SECTION 382 LIMITATION TO [insert name and E.I.N. of the common parent]”;

(C) The date of the ownership change giving rise to the separate section 382 limitation or subgroup section 382 limitation that is being apportioned;

(D) The amount of the separate (or subgroup) section 382 limitation for the taxable year in which the reattribution occurs (determined without reference to any apportionment under this section or §1.1502–95(c));

(E) The amount of each net operating loss carryover or capital loss carryover, and the year in which it arose, of the subsidiary (or subsidiaries) that is subject to the separate section 382 limitation or subgroup section 382 limitation that is being apportioned to the common parent, and the amount of the value element and adjustment element of that limitation that is apportioned to the common parent.

* * * * *

Par. 3a. Immediately following §1.1502–79A, an undesignated center-heading is added to read as follows:

REGULATIONS APPLYING SECTION 382 WITH RESPECT TO TESTING DATES (AND CORPORATIONS JOINING OR LEAVING CONSOLIDATED GROUPS) BEFORE June 25, 1999.

Par. 4. Section §1.1502–90T is amended as follows:

1. Redesignating §1.1502–90T as §1.1502–90A [newly redesignated §1.1502–90A will appear after the center-heading added in Par. 3a.]

2. Revising the section heading and the introductory text of newly designated §1.1502–90A.

3. Redesignating the entries for §1.1502–91T through §1.1502–99T as §1.1502–91A through §1.1502–99A and revising the section headings.

4. Revising the entries for paragraph (a) of newly designated §1.1502–99A.

The revisions read as follows:

§1.1502–90A *Table of contents.*

The following list contains the major headings in §§1.1502–91A through 1.1502–99A:

§1.1502–91A Application of section 382 with respect to a consolidated group generally applicable for testing dates before June 25, 1999.

* * * * *

§1.1502–92A Ownership change of a loss group or a loss subgroup generally applicable for testing dates before June 25, 1999.

* * * * *

§1.1502–93A Consolidated section 382 limitation (or subgroup section 382 limitation) generally applicable for testing dates before June 25, 1999.

* * * * *

§1.1502–94A Coordination with section 382 and the regulations thereunder when a corporation becomes a member of a consolidated group generally applicable for corporations becoming members of a group before June 25, 1999.

* * * * *

§1.1502–95A Rules on ceasing to be a member of a consolidated group (or loss subgroup) generally applicable for corporations ceasing to be members before June 25, 1999.

* * * * *

§1.1502–96A Miscellaneous rules generally applicable for testing dates before June 25, 1999.

* * * * *

§1.1502–97A Special rules under section 382 for members under the jurisdiction of a court in a title 11 or similar case. [Reserved].

§1.1502–98A Coordination with section 383 generally applicable for testing dates

(or members joining or leaving a group) before June 25, 1999.

§1.1502–99A *Effective dates.*

(a) Effective date.

(1) In general.

(2) Anti-duplication rules for recognized built-in gain.

* * * * *

Par. 5. Section 1.1502–91T is amended as follows:

1. Redesignating §1.1502–91T as §1.1502–91A.

2. Revising the section heading of newly designated §1.1502–91A.

3. Amending paragraph (h)(2) by removing the words “or an intercompany obligation” and replacing them with “(or an intercompany obligation disposed of before June 25, 1999)”.

The revision reads as follows:

§1.1502–91A *Application of section 382 with respect to a consolidated group generally applicable for testing dates before June 25, 1999.*

* * * * *

Par. 6. Section 1.1502–92T is revised as §1.1502–92A, and the section heading is amended to read as follows:

§1.1502–92A *Ownership change of a loss group or a loss subgroup generally applicable for testing dates before June 25, 1999.*

* * * * *

Par. 6a. Section 1.1502–93T is amended as follows:

1. Redesignating §1.1502–93T as §1.1502–93A.

2. Revising the section heading of newly redesignated §1.1502–93A.

3. Adding a sentence at the end of paragraph (c).

The additions and revisions read as follows:

§1.1502–93A *Consolidated section 382 limitation (or subgroup section 382 limitation) generally applicable for testing dates before June 25, 1999.*

* * * * *

(c)* * * See §1.1502–99A(a)(2) for a special rule relating to the application of

§1.502–93(c)(2) to consolidated return years for which the due date of the return is after June 25, 1999.

* * * * *

Par. 7. Section 1.1502–94T is amended as follows:

1. Redesignating §1.1502–94T as §1.1502–94A.

2. Revising the section heading of newly redesignated §1.1502–94A.

3. Revising the last sentence of paragraph (b)(4), Example 3(b).

The revision reads as follows:

§1.1502–94A Coordination with section 382 and the regulations thereunder when a corporation becomes a member of a consolidated group) generally applicable for corporations becoming members of a group before June 25, 1999.

* * * * *

(b) * * *

(4) * * *

Example 3. * * *

(b) * * * See also §1.1502–21T in effect prior to June 25, 1999, contained in 26 CFR Part 1, revised April 1, 1999, or §1.1502–21, as applicable.

* * * * *

Par. 8. Redesignate §1.1502–95T as §1.1502–95A and revise the section heading to read as follows:

§1.1502–95A Rules on ceasing to be a member of a consolidated group generally applicable for corporations ceasing to be members before June 25, 1999.

* * * * *

Par. 9. Redesignate §1.1502–96T as §1.1502–96A and revise the section heading to read as follows:

§1.1502–96A. Miscellaneous rules generally applicable for testing dates before June 25, 1999.

* * * * *

Par. 10. Redesignate §1.1502–97T as §1.1502–97A and revise the section heading to read as follows:

§1.1502–97A Special rules under section 382 for members under the jurisdiction of a court in a title 11 or similar case.

[Reserved].

* * * * *

Par. 11. Redesignate §1.1502–98T as §1.1502–98A and revise the section heading to read as follows:

§1.1502–98A Coordination with section 383 generally applicable for testing dates (or members joining or leaving a group) before June 25, 1999.

* * * * *

Par. 12. Section 1.1502–99T is amended as follows:

1. Redesignating §1.1502–99T as §1.1502–99A.

2. Revising the section heading.

3. Revising paragraph (a).

4. Amending paragraph (c)(2)(i) by removing the language “(relating to the apportionment” in the first sentence and adding “and (b)(2)(ii)(relating to the apportionment”.

The revisions read as follows:

§1.1502–99A Effective dates.

(a) *Effective date*—(1) *In general.* Except as provided in §1.1502–99(b), §§1.1502–91A through 1.1502–96A and 1.1502–98A apply to any testing date on or after January 1, 1997, and before June 25, 1999. Sections 1.1502–94A through 1.1502–96A also apply on any date on or after January 1, 1997, and before June 25, 1999, on which a corporation becomes a member of a group or on which a corporation ceases to be a member of a loss group (or a loss subgroup).

(2) *Anti-duplication rules for recognized built-in gain.* Section 1.1502–93(c)(2)(relating to recognized built-in gain of a loss group or loss subgroup) applies to taxable years for which the due date for income tax returns (without extensions) is after June 25, 1999.

* * * * *

Par. 13. Sections 1.1502–90 through 1.1502–99 are added to read as follows:

§1.1502–90 Table of contents.

The following list contains the major headings in §§1.1502–91 through 1.1502–99:

§1.1502–91 Application of section 382 with respect to a consolidated group.

a. Determination and effect of an ownership change.

(1) In general.

(2) Special rule for post-change year that includes the change date.

(3) Cross-reference.

(b) Definitions and nomenclature.

(c) Loss group.

(1) Defined.

(2) Coordination with rule that ends separate tracking.

(3) Example.

(d) Loss subgroup.

(1) Net operating loss carryovers.

(2) Net unrealized built-in loss.

(3) Loss subgroup parent.

(4) Election to treat loss subgroup parent requirement as satisfied.

(5) Principal purpose of avoiding a limitation.

(6) Special rules.

(7) Examples.

(e) Pre-change consolidated attribute.

(1) Defined.

(2) Example.

(f) Pre-change subgroup attribute.

(1) Defined.

(2) Example.

(g) Net unrealized built-in gain and loss.

(1) In general.

(2) Members included.

(i) Consolidated group with a net operating loss.

(ii) Determination whether a consolidated group has a net unrealized built-in loss.

(iii) Loss subgroup with net operating loss carryovers.

(iv) Determination whether subgroup has a net unrealized built-in loss.

(v) Separate determination of section 382 limitation for recognized built-in losses and net operating losses.

(3) Coordination with rule that ends separate tracking.

(4) Acquisitions of built-in gain or loss assets.

- (5) Indirect ownership.
- 2. Common parent not common parent for five years.
- (h) Recognized built-in gain or loss.
 - (1) In general. [Reserved]
 - (2) Disposition of stock or an intercompany obligation of a member.
 - (3) Intercompany transactions.
 - (4) Exchanged basis property.
 - (i) [Reserved]
 - (j) Predecessor and successor corporations.

§1.1502–92 Ownership change of a loss group or a loss subgroup.

- (a) Scope.
- (b) Determination of an ownership change.
 - (1) Parent change method.
 - (i) Loss group.
 - (ii) Loss subgroup.
 - (iii) Special rule if election regarding section 1504(a)(1) relationship is made.
 - (2) Examples.
 - (3) Special adjustments.
 - (i) Common parent succeeded by a new common parent.
 - (ii) Newly created loss subgroup parent.
 - (iii) Examples.
 - (4) End of separate tracking of certain losses.
- (c) Supplemental rules for determining ownership change.
 - (1) Scope.
 - (2) Cause for applying supplemental rule.
 - (3) Operating rules.
 - (4) Supplemental ownership change rules.
 - (i) Additional testing dates for the common parent (or loss subgroup parent).
 - (ii) Treatment of subsidiary stock as stock of the common parent (or loss subgroup parent).
 - (iii) Different testing periods.
 - (iv) Disaffiliation of a subsidiary.
 - (v) Subsidiary stock acquired first.
 - (vi) Anti-duplication rule.
 - (5) Examples.
 - (d) Testing period following ownership change under this section.
 - (e) Information statements.
 - (1) Common parent of a loss group.
 - (2) Abbreviated statement with respect to loss subgroups.

§1.1502–93 Consolidated section 382 limitation (or subgroup section 382 limitation).

- (a) Determination of the consolidated section 382 limitation (or subgroup section 382 limitation).
 - (1) In general.
 - (2) Coordination with apportionment rule.
- (b) Value of the loss group (or loss subgroup).
 - (1) Stock value immediately before ownership change.
 - (2) Adjustment to value.
 - (i) In general.
 - (ii) Anti-duplication.
 - (3) Examples.
- (c) Recognized built-in gain of a loss group or loss subgroup.
 - (1) In general.
 - (2) Adjustments.
 - (d) Continuity of business.
 - (1) In general.
 - (2) Example.
 - (e) Limitations of losses under other rules.

§1.1502–94 Coordination with section 382 and the regulations thereunder when a corporation becomes a member of a consolidated group.

- (a) Scope.
 - (1) In general.
 - (2) Successor corporation as new loss member.
 - (3) Coordination in the case of a loss subgroup.
 - (4) End of separate tracking of certain losses.
 - (5) Cross-reference.
- (b) Application of section 382 to a new loss member.
 - (1) In general.
 - (2) Adjustment to value.
 - (3) Pre-change separate attribute defined.
 - (4) Examples.
- (c) Built-in gains and losses.
- (d) Information statements.

§1.1502–95 Rules on ceasing to be a member of a consolidated group (or loss subgroup).

- (a) In general.
 - (1) Consolidated group.
 - (2) Election by common parent.
 - (3) Coordination with §§1.1502–91 through 1.1502–93.

- (b) Separate application of section 382 when a member leaves a consolidated group.
 - (1) In general.
 - (2) Effect of a prior ownership change of the group.
 - (3) Application in the case of a loss subgroup.
 - (4) Examples.
- (c) Apportionment of a consolidated section 382 limitation.
 - (1) In general.
 - (2) Amount which may be apportioned.
 - (i) Consolidated section 382 limitation.
 - (ii) Net unrealized built-in gain.
 - (3) Effect of apportionment on the consolidated group.
 - (i) Consolidated section 382 limitation.
 - (ii) Net unrealized built-in gain.
 - (4) Effect on corporations to which an apportionment is made.
 - (i) Consolidated section 382 limitation.
 - (ii) Net unrealized built-in gain.
 - (5) Deemed apportionment when loss group terminates.
 - (6) Appropriate adjustments when former member leaves during the year.
 - (7) Examples.
- (d) Rules pertaining to ceasing to be a member of a loss subgroup.
 - (1) In general.
 - (2) Exceptions.
 - (3) Examples.
 - (e) Allocation of net unrealized built-in loss.
 - (1) In general.
 - (2) Amount of allocation.
 - (i) In general.
 - (ii) Transferred basis property and deferred gain or loss.
 - (iii) Assets for which gain or loss has been recognized.
 - (iv) Exchanged basis property.
 - (v) Two or more members depart during the same year.
 - (vi) Anti-abuse rule.
 - (3) Effect of the allocation on the consolidated group.
 - (4) Effect on corporations to which the allocation is made.
 - (5) Subgroup principles.
 - (6) Apportionment of consolidated section 382 limitation (or subgroup section 382 limitation).
 - (i) In general.
 - (ii) Special rule for former members that become members of the same consolidated group.

- (7) Examples.
- (8) Reporting requirement.
- (f) Filing the election to apportion the section 382 limitation and net unrealized built-in gain.
- (1) Form of the election to apportion.
- (2) Signing of the election.
- (3) Filing of the election.
- (4) Revocation of election.

§1.1502-96 Miscellaneous rules.

- c. End of separate tracking of losses.
 - (1) Application.
 - (2) Effect of end of separate tracking.
 - (i) Net operating loss carryovers.
 - (ii) Net unrealized built-in losses.
 - (iii) Common parent not common parent for five years.
 - (3) Continuing effect of end of separate tracking.
 - (i) In general.
 - (ii) Example.
 - (4) Special rule for testing period.
 - (5) Limits on effects of end of separate tracking.
- (b) Ownership change of subsidiary.
 - (1) Ownership change of a subsidiary because of options or plan or arrangement.
 - (2) Effect of the ownership change.
 - (i) In general.
 - (ii) Pre-change losses.
 - (3) Coordination with §§1.1502-91, 1.1502-92, and 1.1502-94.
 - (4) Example.
- (c) Continuing effect of an ownership change.
- (d) Losses reattributed under §1.1502-20(g).
 - (1) In general.
 - (2) Deemed section 381(a) transaction.
 - (3) Rules relating to owner shifts.
 - (i) In general.
 - (ii) Examples.
 - (4) Rules relating to the section 382 limitation.
 - (i) Reattributed loss is a pre-change separate attribute of a new loss member.
 - (ii) Reattributed loss is a pre-change subgroup attribute.
 - (iii) Potential application of section 382(l)(1).
 - (iv) Duplication or omission of value.
 - (v) Special rule for continuity of business requirement.
 - (5) Election to reattribute section 382 limitation.

- (i) Effect of election.
- (ii) Examples.
- (e) Time and manner of making election under §1.1502-91(d)(4).
 - (1) In general.
 - (2) Election statement.

§1.1502-97 Special rules under section 382 for members under the jurisdiction of a court in a title 11 or similar case.[Reserved].

§1.1502-98 Coordination with section 383.

§1.1502-99 Effective dates.

- (a) Effective date.
- (b) Special rules.
 - (1) Election to treat subgroup parent requirement as satisfied.
 - 4. Principal purpose of avoiding a limitation.
 - (3) Ceasing to be a member of a loss subgroup.
 - (i) Ownership change of a loss subgroup.
 - (ii) Expiration of 5-year period.
 - (4) Reattribution of net operating loss carryovers under §1.1502-20(g).
 - (5) Election to apportion net unrealized built-in gain.
 - (c) Testing period may include a period beginning before June 25, 1999.
 - (1) In general.
 - (2) Transition rule for net unrealized built-in losses.

§1.1502-91 Application of section 382 with respect to a consolidated group.

(a) *Determination and effect of an ownership change*—(1) *In general.* This section and §§1.1502-92 and 1.1502-93 set forth the rules for determining an ownership change under section 382 for members of consolidated groups and the section 382 limitations with respect to attributes described in paragraphs (e) and (f) of this section. These rules generally provide that an ownership change and the section 382 limitation are determined with respect to these attributes for the group (or loss subgroup) on a single entity basis and not for its members separately. Following an ownership change of a loss group (or a loss subgroup) under §1.1502-92, the amount of consolidated taxable income for any post-change year which may be offset by pre-change con-

solidated attributes (or pre-change subgroup attributes) shall not exceed the consolidated section 382 limitation (or subgroup section 382 limitation) for such year as determined under §1.1502-93.

(2) *Special rule for post-change year that includes the change date.* If the post-change year includes the change date, section 382(b)(3)(A) is applied so that the consolidated section 382 limitation (or subgroup section 382 limitation) does not apply to the portion of consolidated taxable income that is allocable to the period in the year on or before the change date. See generally §1.382-6 (relating to the allocation of income and loss). The allocation of consolidated taxable income for the post-change year that includes the change date must be made before taking into account any consolidated net operating loss deduction (as defined in §1.1502-21(a)).

(3) *Cross-reference.* See §§1.1502-94 and 1.1502-95 for rules that apply section 382 to a corporation that becomes or ceases to be a member of a group or loss subgroup.

(b) *Definitions and nomenclature.* For purposes of this section and §§1.1502-92 through 1.1502-99, unless otherwise stated:

(1) The definitions and nomenclature contained in section 382 and the regulations thereunder (including the nomenclature and assumptions relating to the examples in §1.382-2T(b)) and this section and §§1.1502-92 through 1.1502-99 apply.

(2) In all examples, all groups file consolidated returns, all corporations file their income tax returns on a calendar year basis, the only 5-percent shareholder of a corporation is a public group, the facts set forth the only owner shifts during the testing period, no election is made under paragraph (d)(4) of this section, and each asset of a corporation has a value equal to its adjusted basis.

(3) As the context requires, references to §§1.1502-91 through 1.1502-96 include references to corresponding provisions of §§1.1502-91A through 1.1502-96A. For example, a reference to an ownership change under §1.1502-92 in §1.1502-95(b) can include a reference to an ownership change under §1.1502-92A.

(c) *Loss group*—(1) *Defined.* A loss group is a consolidated group that—

(i) Is entitled to use a net operating loss carryover to the taxable year that did not arise (and is not treated under §1.1502-21(c) as arising) in a SRLY;

(ii) Has a consolidated net operating loss for the taxable year in which a testing date of the common parent occurs (determined by treating the common parent as a loss corporation); or

(iii) Has a net unrealized built-in loss (determined under paragraph (g) of this section by treating the date on which the determination is made as though it were a change date).

(2) *Coordination with rule that ends separate tracking.* A consolidated group may be a loss group because a member's losses that arose in (or are treated as arising in) a SRLY are treated as described in paragraph (c)(1)(i) of this section. See §1.1502-96(a).

(3) *Example.* The following example illustrates the principles of this paragraph (c):

Example. Loss group. (i) L and L1 file separate returns and each has a net operating loss carryover arising in Year 1 that is carried over to Year 2. A owns 40 shares and L owns 60 shares of the 100 outstanding shares of L1 stock. At the close of Year 1, L buys the 40 shares of L1 stock from A. For Year 2, L and L1 file a consolidated return. The following is a graphic illustration of these facts:

(ii) L and L1 become a loss group at the beginning of Year 2 because the group is entitled to use the Year 1 net operating loss carryover of L, the common parent, which did not arise (and is not treated under §1.1502-21(c) as arising) in a SRLY. See §1.1502-94 for rules relating to the application of section 382 with respect to L1's net operating loss carryover from Year 1 which did arise in a SRLY.

(d) *Loss subgroup*—(1) *Net operating loss carryovers.* Two or more corporations that become members of a consolidated group (the current group) compose a loss subgroup if—

(i) They were affiliated with each other in another group (the former group), whether or not the group was a consolidated group;

(ii) They bear the relationship described in section 1504(a)(1) to each other through a loss subgroup parent immediately after they become members of the current group (or are deemed to bear that relationship as a result of an election described in paragraph (d)(4) of this section); and

(iii) At least one of the members carries over a net operating loss that did not arise (and is not treated under §1.1502-21(c) as arising) in a SRLY with respect to the former group.

(2) *Net unrealized built-in loss.* Two or more corporations that become members of a consolidated group compose a loss subgroup if they—

(i) Have been continuously affiliated with each other for the 5 consecutive year period ending immediately before they become members of the group;

(ii) Bear the relationship described in section 1504(a)(1) to each other through a loss subgroup parent immediately after they become members of the current group (or are deemed to bear that relationship as a result of an election described in paragraph (d)(4) of this section); and

(iii) Have a net unrealized built-in loss (determined under paragraph (g) of this section on the day they become members of the group by treating that day as though it were a change date).

(3) *Loss subgroup parent.* A loss subgroup parent is the corporation that bears the same relationship to the other members of the loss subgroup as a common parent bears to the members of a group.

(4) *Election to treat loss subgroup parent requirement as satisfied*—(i) *In general.* Solely for purposes of paragraphs (d)(1)(i) and (2)(ii) of this section, two or more corporations that become members of a consolidated group at the same time and that were affiliated with each other immediately before becoming members of the group are deemed to bear a section 1504(a)(1) relationship to each other immediately after they become members of the group if the common parent of that group makes an election under this paragraph (d)(4) with respect to those members. See §1.1502-96(e) for the time and manner of making the election.

(ii) *Members included.* An election under this paragraph (d)(4) includes all corporations that become members of the

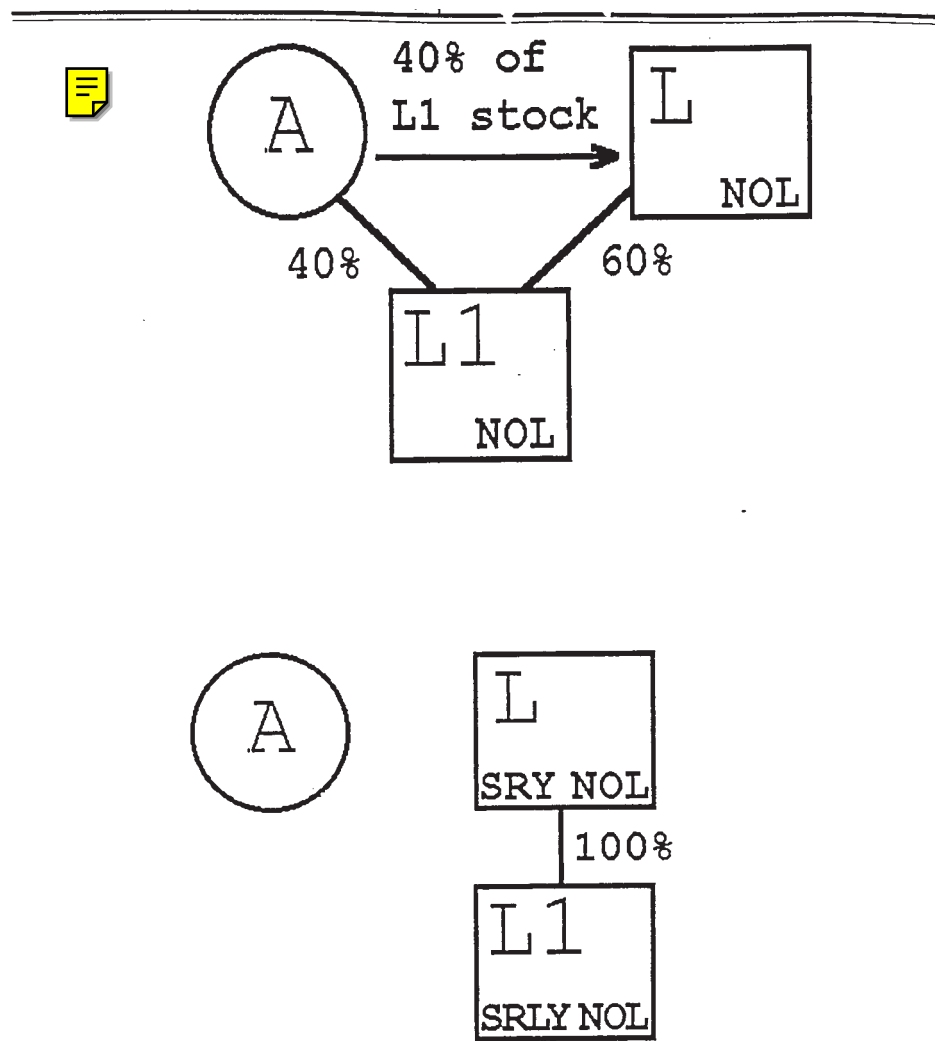

current group at the same time and that were affiliated with each other immediately before they become members of the current group.

(iii) *Each member included treated as loss subgroup parent.* If the members to which this election applies are a loss subgroup described in paragraph (d)(1) or (2) of this section, then each member is treated as a loss subgroup parent. See §1.1502-92(b)(1)(iii) for special rules relating to an ownership change of a loss subgroup if the election under this paragraph (d)(4) is made.

(5) *Principal purpose of avoiding a limitation.* The corporations described in paragraphs (d)(1) or (2) of this section do not compose a loss subgroup if any one of them is formed, acquired, or availed of with a principal purpose of avoiding the application of, or increasing any limitation under, section 382. Instead, §1.1502-94 applies with respect to the attributes of each such corporation. Any member excluded from a loss subgroup, if excluded with a principal purpose of so avoiding or increasing any section 382 limitation, is treated as included in the loss subgroup. This paragraph (d)(5) does not apply solely because, in connection with becoming members of the group, the members of a group (or loss subgroup) are rearranged (or, in the case of the preceding sentence, are not rearranged) to bear a relationship to the other members described in section 1504(a)(1).

(6) *Special rules.* See §1.1502-95(d) for rules concerning when a corporation ceases to be a member of a loss subgroup, and for certain exceptions that may apply if a member does not continue to satisfy the loss subgroup parent requirement within the current group. See also §1.1502-96(a) for a special rule regarding the end of separate tracking of SRLY losses of a member that has an ownership change or that has been a member of a group for at least 5 consecutive years.

(7) *Examples.* The following examples illustrate the principles of this paragraph (d):

Example 1. Loss subgroup. (i) P owns all the L stock and L owns all the L1 stock. The P group has a consolidated net operating loss arising in Year 1 that is carried to Year 2. On May 2, Year 2, P sells all the stock of L to A, and L and L1 thereafter file consolidated returns. A portion of the Year 1 consolidated net operating loss is apportioned under

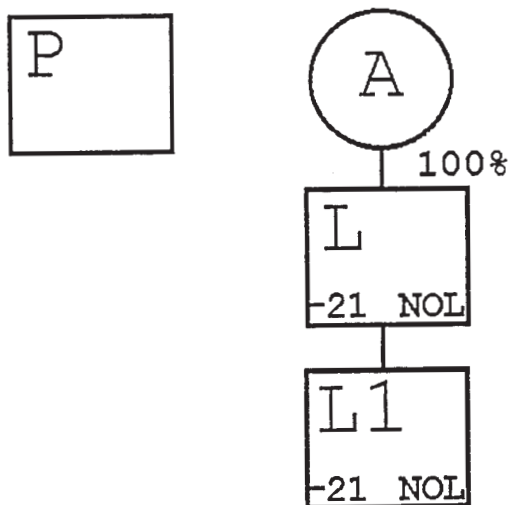
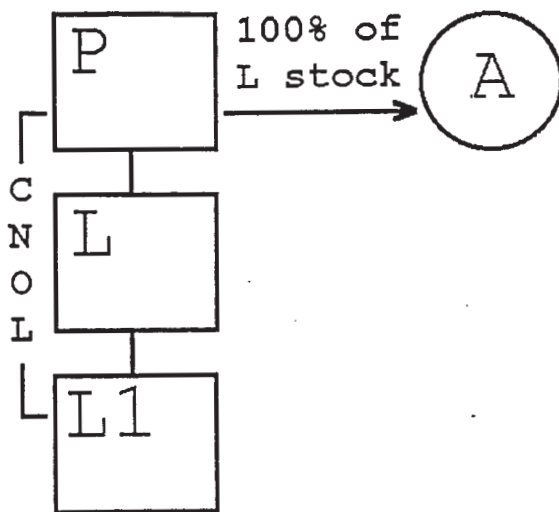

§1.1502-21(b) to each of L and L1, which they carry over to Year 2. The following is a graphic illustration of these facts:

(ii) (a) L and L1 compose a loss subgroup within the meaning of paragraph (d)(1) of this section because—

(A) They were affiliated with each other in the P group (the former group);

(B) They bear a relationship described in section 1504(a)(1) to each other through a loss subgroup parent (L) immediately after they became members of the L group; and

(C) At least one of the members (here, both L and L1) carries over a net operating loss to the L group (the current group) that did not arise in a SRLY with respect to the P group.

(b) Under paragraph (d)(3) of this section, L is the loss subgroup parent of the L loss subgroup.

Example 2. Loss subgroup—section 1504(a)(1) relationship. (i) P owns all the stock of L and L1. L owns all the stock of L2. L1 and L2 own 40 percent

and 60 percent of the stock of L3, respectively. The P group has a consolidated net operating loss arising in Year 1 that is carried over to Year 2. On May 22, Year 2, P sells all the stock of L and L1 to P1, the common parent of another consolidated group. The Year 1 consolidated net operating loss is apportioned under §1.1502-21(b), and each of L, L1, L2, and L3 carries over a portion of such loss to the first consolidated return year of the P1 group ending after the acquisition. The following is a graphic illustration of these facts:

(ii) L and L2 compose a loss subgroup within the meaning of paragraph (d)(1) of this section. Neither L1 nor L3 is included in a loss subgroup because neither bears a relationship described in section 1504(a)(1) through a loss subgroup parent to any other member of the former group immediately after becoming members of the P1 group.

Example 3. Loss subgroup—section 1504(a)(1) relationship. The facts are the same as in *Example 2*, except that the stock of L1 is transferred to L in

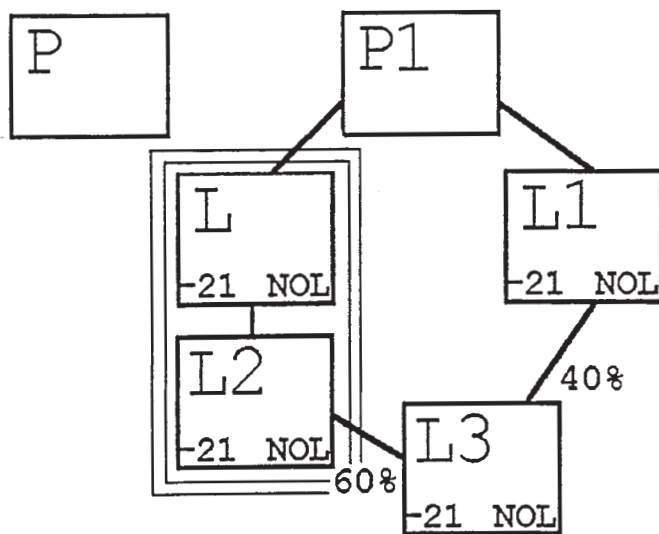
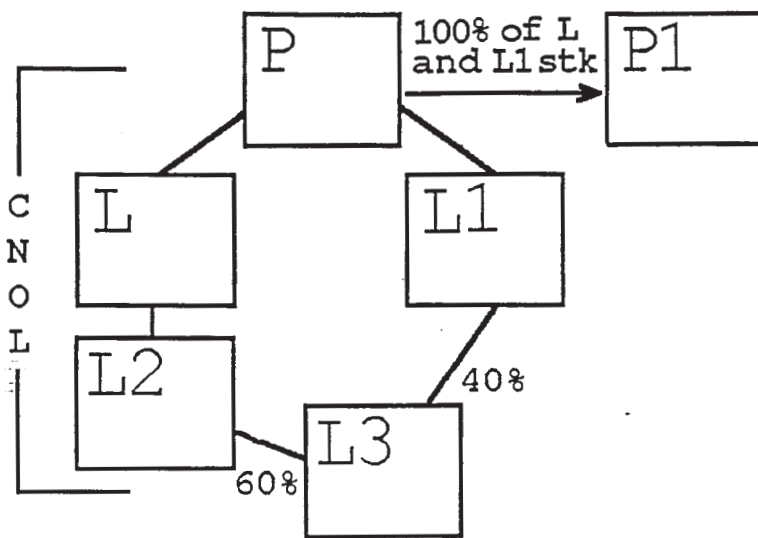

connection with the sale of the L stock to P1. L, L1, L2, and L3 compose a loss subgroup within the meaning of paragraph (d)(1) of this section because—

- (i) They were affiliated with each other in the P group (the former group);
- (ii) They bear a relationship described in section 1504(a)(1) to each other through a loss subgroup parent (L) immediately after they become members of the P1 group; and
- (iii) At least one of the members (here, each of L, L1, L2, and L3) carries over a net operating loss to the P1 group (the current group).

Example 4. Loss subgroup—elective section 1504(a)(1) relationship. The facts are the same as in Example 2, except that P1 makes the election under paragraph (d)(4) of this section. The election includes L, L1, L2, and L3 (even though L and L2 would compose a loss subgroup without regard to the election) because they become members of the current group (the P1 group) at the same time and were affiliated with each other in the P group immediately before they became members of the P1

group. As a result of the election, L, L1, L2, and L3 are treated as satisfying the requirement that they bear the relationship described in section 1504(a)(1) to each other through a loss subgroup parent immediately after they become members of the P1 group. L, L1, L2, and L3 compose a loss subgroup within the meaning of paragraph (d)(1) of this section.

(e) Pre-change consolidated attribute—(1) Defined. A pre-change consolidated attribute of a loss group is—

- (i) Any loss described in paragraph (c)(1)(i) or (ii) of this section (relating to the definition of loss group) that is allocable to the period ending on or before the change date; and
- (ii) Any recognized built-in loss of the loss group.

(2) Example. The following example illustrates the principle of this paragraph (e):

Example. Pre-change consolidated attribute. (i) The L group has a consolidated net operating loss arising in Year 1 that is carried over to Year 2. The L loss group has an ownership change at the beginning of Year 2.

(ii) The net operating loss carryover of the L loss group from Year 1 is a pre-change consolidated attribute because the L group was entitled to use the loss in Year 2 and therefore the loss was described in paragraph (c)(1)(i) of this section. Under paragraph (a)(2)(i) of this section, the amount of consolidated taxable income of the L group for Year 2 that may be offset by this loss carryover may not exceed the consolidated section 382 limitation of the L group for that year. See §1.1502-93 for rules relating to the computation of the consolidated section 382 limitation.

(f) Pre-change subgroup attribute—(1) Defined. A pre-change subgroup attribute of a loss subgroup is—

- (i) Any net operating loss carryover described in paragraph (d)(1)(iii) of this section (relating to the definition of loss subgroup); and
- (ii) Any recognized built-in loss of the loss subgroup.

(2) Example. The following example illustrates the principle of this paragraph (f):

Pre-change subgroup attribute. (i) P is the common parent of a consolidated group. P owns all the stock of L, and L owns all the stock of L1. L2 is not a member of an affiliated group, and has a net operating loss arising in Year 1 that is carried over to Year 2. On December 11, Year 2, L1 acquires all the stock of L2, causing an ownership change of L2. During Year 2, the P group has a consolidated net operating loss that is carried over to Year 3. On November 2, Year 3, M acquires all the L stock from P. M, L, L1, and L2 thereafter file consolidated returns. All of the P group Year 2 consolidated net operating loss is apportioned under §1.1502-21(b) to L and L2, which they carry over to the M group.

(ii)(a) L, L1, and L2 compose a loss subgroup because—

- (1) They were affiliated with each other in the P group (the former group);
- (2) They bear a relationship described in section 1504(a)(1) to each other through a loss subgroup parent (L) immediately after they became members of the L group; and
- (3) At least one of the members (here, both L and L2) carries over a net operating loss to the M group (the current group) that is described in paragraph (d)(1)(iii) of this section.

(b) For this purpose, L2's loss from Year 1 that was a SRLY loss with respect to the P group (the former group) is described in paragraph (d)(1)(iii) of this section because L2 had an ownership change on becoming a member of the P group (see §1.1502-96(a)) on December 11, Year 2. Starting on December 12, Year 2, the P group no longer separately tracked owner shifts of the stock of L1 with respect to the Year 1 loss. M's acquisition results in an ownership change of L, and therefore the L loss subgroup under §1.1502-92(a)(2). See §1.1502-93

for rules governing the computation of the subgroup section 382 limitation.

(iii) In the M group, L2's Year 1 loss continues to be subject to a section 382 limitation resulting from the ownership change that occurred on December 11, Year 2. See §1.1502-96(c).

(g) *Net unrealized built-in gain and loss*—(1) *In general.* The determination whether a consolidated group (or loss subgroup) has a net unrealized built-in gain or loss under section 382(h)(3) is based on the aggregate amount of the separately computed net unrealized built-in gains or losses of each member that is included in the group (or loss subgroup) under paragraph (g)(2) of this section, including items of built-in income and deduction described in section 382(h)(6). Thus, for example, amounts deferred under section 267, or under §1.1502-13 (other than amounts deferred with respect to the stock of a member (or an intercompany obligation) included in the group (or loss subgroup) under paragraph (g)(2) of this section) are built-in items. The threshold requirement under section 382(h)(3)(B) applies on an aggregate basis and not on a member-by-member basis. The separately computed amount of a member included in a group or loss subgroup does not include any unrealized built-in gain or loss on stock (including stock described in section 1504(a)(4) and §1.382-2T(f)(18)(ii) and (iii)) of another member included in the group or loss subgroup (or an intercompany obligation). However, a member of a group or loss subgroup includes in its separately computed amount the unrealized built-in gain or loss on stock (but not on an intercompany obligation) of another member not included in the group or loss subgroup. If a member is not included in the determination whether a group (or subgroup) has a net unrealized built-in loss under paragraph (g)(2)(ii) or (iv) of this section, that member is not included in the loss group or loss subgroup. See §1.1502-94(c) (relating to built-in gain or loss of a new loss member) and §1.1502-96(a) (relating to the end of separate tracking of certain losses).

(2) *Members included*—(i) *Consolidated group with a net operating loss.* The members included in the determination whether a consolidated group described in paragraph (c)(1)(i) or (ii) of this section (relating to loss groups with net

operating losses) has a net unrealized built-in gain are all members of the consolidated group on the day that the determination is made.

(ii) *Determination whether a consolidated group has a net unrealized built-in loss.* The members included in the determination whether a consolidated group is a loss group described in paragraph (c)(1)(iii) of this section are—

(A) The common parent and all other members that have been affiliated with the common parent for the 5 consecutive year period ending on the day that the determination is made;

(B) Any other member that has a net unrealized built-in loss determined under paragraph (g)(1) of this section on the date that the determination is made, and that is neither a new loss member described in §1.1502-94(a)(1)(ii) nor a member of a loss subgroup described in paragraph (d)(2) of this section;

(C) Any new loss member described in §1.1502-94(a)(1)(ii) that has a net unrealized built-in gain determined under paragraph (g)(1) of this section on the day that the determination is made; and

(D) The members of a loss subgroup described in paragraph (d)(2) of this section if the members of the subgroup have, in the aggregate, a net unrealized built-in gain on the day that the determination is made.

(iii) *Loss subgroup with net operating loss carryovers.* The members included in the determination whether a loss subgroup described in paragraph (d)(1) of this section (relating to loss subgroups with net operating loss carryovers) has a net unrealized built-in gain are all members of the loss subgroup on the day that the determination is made.

(iv) *Determination whether subgroup has a net unrealized built-in loss.* The members included in the determination whether a subgroup has a net unrealized built-in loss are those members described in paragraphs (d)(2)(i) and (ii) of this section.

(v) *Separate determination of section 382 limitation for recognized built-in losses and net operating losses.* In determining whether a loss group described in paragraph (c)(1)(i) or (ii) of this section (relating to loss groups that have net operating loss carryovers) has a net unrealized built-in gain which, if recognized, in-

creases the consolidated section 382 limitation, the group includes, under paragraph (g)(2)(i) of this section, all of its members on the day the determination is made. Under paragraph (g)(2)(ii) of this section, however, for purposes of determining whether a group has a net unrealized built-in loss described in paragraph (c)(1)(iii) of this section, not all members of the consolidated group may be included. Thus, a consolidated group may have recognized built-in gains that increase the amount of consolidated taxable income that may be offset by its pre-change net operating loss carryovers that did not arise (and are not treated as arising) in a SRLY, and also may have recognized built-in losses the absorption of which is limited. Similar results may obtain for loss subgroups under paragraphs (g)(2)(iii) and (iv) of this section. See §1.1502-93(c)(2) for rules prohibiting the use of recognized built-in gains to increase the amount of consolidated taxable income that can be offset by recognized built-in losses.

(3) *Coordination with rule that ends separate tracking.* See §1.1502-96(a) for special rules relating to members (or loss subgroups) that have an ownership change within six months before, on, or after becoming a member of the group.

(4) *Acquisitions of built-in gain or loss assets.* A member of a consolidated group (or loss subgroup) may not, in determining its separately computed net unrealized built-in gain or loss, include any gain or loss with respect to assets acquired with a principal purpose to affect the amount of its net unrealized built-in gain or loss. A group (or loss subgroup) may not, in determining its net unrealized built-in gain or loss, include any gain or loss of a member acquired with a principal purpose to affect the amount of its net unrealized built-in gain or loss.

(5) *Indirect ownership.* A member's separately computed net unrealized built-in gain or loss is adjusted to the extent necessary to prevent any duplication of unrealized gain or loss attributable to the member's indirect ownership interest in another member through a nonmember if the member has a 5-percent or greater ownership interest in the nonmember.

(6) *Common parent not common parent for five years.* If the common parent has become the common parent of an existing

group within the previous 5 year period in a transaction described in §1.1502-75(d)(2)(ii) or (3), appropriate adjustments must be made in applying paragraph (g)(2)(ii)(A) of this section so that corporations that have not been members of the group for five years are not included. In such a case, references to the common parent in paragraph (g)(2)(ii)(A) of this section are to the former common parent. Thus, members of the group remaining in existence (including the new common parent) that have not been affiliated with the former common parent (or that have not been members of that group) for the five consecutive year period ending on the day that the determination is made are not included under paragraph (g)(2)(ii)(A) of this section. See, however, §1.1502-96(a)(2) for special rules relating to members (or loss subgroups) that have an ownership change within six months before, on, or after the time that the member becomes a member of the group.

(h) *Recognized built-in gain or loss—*
(1) *In general.* [Reserved].

(2) *Disposition of stock or an intercompany obligation of a member.* Gain or loss recognized by a member on the disposition of stock (including stock described in section 1504(a)(4) and §1.382-2T(f)(18)(ii) and (iii)) of another member is treated as a recognized gain or loss for purposes of section 382(h)(2) (unless disallowed under §1.1502-20 or otherwise), even though gain or loss on such stock was not included in the determination of a net unrealized built-in gain or loss under paragraph (g)(1) of this section. Gain or loss recognized by a member with respect to an intercompany obligation is treated as recognized gain or loss only to the extent (if any) the transaction gives rise to aggregate income or loss within the consolidated group.

(3) *Intercompany transactions.* Gain or loss that is deferred under provisions such as section 267 and §1.1502-13 is treated as recognized built-in gain or loss only to the extent taken into account by the group during the recognition period. See also §1.1502-13(c)(7) *Example 10.*

(4) *Exchanged basis property.* If the adjusted basis of any asset is determined, directly or indirectly, in whole or in part, by reference to the adjusted basis of another asset held by the member at the be-

ginning of the recognition period, the asset is treated, with appropriate adjustments, as held by the member at the beginning of the recognition period.

(i) [Reserved]

(j) *Predecessor and successor corporations.* A reference in this section and §§1.1502-92 through 1.1502-99 to a corporation, member, common parent, loss subgroup parent, or subsidiary includes, as the context may require, a reference to a predecessor or successor corporation as defined in §1.1502-1(f)(4). For example, the determination whether a successor satisfies the continuous affiliation requirement of paragraph (d)(2)(i) or (g)(2)(ii) of this section is made by reference to its predecessor.

§1.1502-92 Ownership change of a loss group or a loss subgroup.

(a) *Scope.* This section provides rules for determining if there is an ownership change for purposes of section 382 with respect to a loss group or a loss subgroup. See §1.1502-94 for special rules for determining if there is an ownership change with respect to a new loss member and §1.1502-96(b) for special rules for determining if there is an ownership change of a subsidiary.

(b) *Determination of an ownership change—*(1) *Parent change method—*(i) *Loss group.* A loss group has an ownership change if the loss group's common parent has an ownership change under section 382 and the regulations thereunder. Solely for purposes of determining whether the common parent has an ownership change—

(A) The losses described in §1.1502-91(c) are treated as net operating losses (or a net unrealized built-in loss) of the common parent; and

(B) The common parent determines the earliest day that its testing period can begin by reference to only the attributes that make the group a loss group under §1.1502-91(c).

(ii) *Loss subgroup.* A loss subgroup has an ownership change if the loss subgroup parent has an ownership change under section 382 and the regulations thereunder. The principles of §1.1502-95(b) (relating to ceasing to be a member of a consolidated group) apply in determining whether the loss subgroup parent

has an ownership change. Solely for purposes of determining whether the loss subgroup parent has an ownership change—

(A) The losses described in §1.1502-91(d) are treated as net operating losses (or a net unrealized built-in loss) of the loss subgroup parent;

(B) The day that the members of the loss subgroup become members of the group (or a loss subgroup) is treated as a testing date within the meaning of §1.382-2(a)(4); and

(C) The loss subgroup parent determines the earliest day that its testing period can begin under §1.382-2T(d)(3) by reference to only the attributes that make the members a loss subgroup under §1.1502-91(d).

(iii) *Special rule if election regarding section 1504(a)(1) relationship is made—*

(A) *Ownership change of deemed loss subgroup parent is an ownership change of loss subgroup.* If the common parent makes an election under §1.1502-91(d)(4), each of the members in the loss subgroup is treated as the loss subgroup parent for purposes of determining whether the loss subgroup has an ownership change under section 382 and the regulations thereunder on or after the day the members become members of the group.

(B) *Exception.* Paragraph (b)(1)(iii)(A) of this section does not apply to cause an ownership change of a loss subgroup if a deemed loss subgroup parent has an ownership change upon (or after) ceasing to be a member of the current group.

(2) *Examples.* The following examples illustrate the principles of this paragraph (b):

Example 1. Loss group—ownership change of the common parent. (i) A owns all the L stock. L owns 80 percent and B owns 20 percent of the L1 stock. For Year 1, the L group has a consolidated net operating loss that resulted from the operations of L1 and that is carried over to Year 2. The value of the L stock is \$1000. The total value of the L1 stock is \$600 and the value of the L1 stock held by B is \$120. The L group is a loss group under §1.1502-91(c)(1) because it is entitled to use its net operating loss carryover from Year 1. On August 15, Year 2, A sells 51 percent of the L stock to C. The following is a graphic illustration of these facts:

(ii) Under paragraph (b)(1)(i) of this section, section 382 and the regulations thereunder are applied to L to determine whether it (and therefore the L loss group) has an ownership change with respect to its net operating loss carryover from Year 1 attrib-

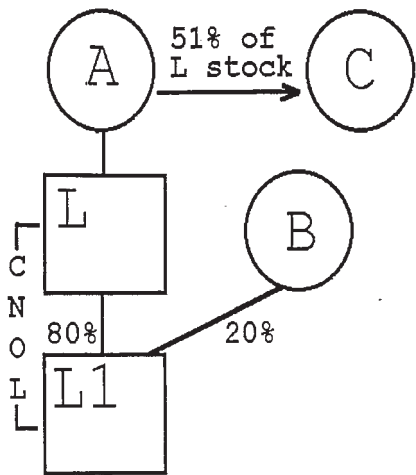

transferable to L1 on August 15, Year 2. The sale of the L stock to C causes an ownership change of L under §1.382-2T and of the L group under paragraph (b)(1)(i) of this section. The amount of consolidated taxable income of the L loss group for any post-change taxable year that may be offset by its pre-change consolidated attributes (that is, the net operating loss carryover from Year 1 attributable to L1) may not exceed the consolidated section 382 limitation for the L loss group for the taxable year.

Example 2. Loss group—owner shifts of subsidiaries disregarded. (i) The facts are the same as in Example 1, except that on August 15, Year 2, A sells only 49 percent of the L stock to C and, on December 12, Year 3, in an unrelated transaction, B sells the 20 percent of the L1 stock to D. A's sale of the L stock to C does not cause an ownership change of L under §1.382-2T nor of the L loss group under paragraph (b)(1)(i) of this section. The following is a graphic illustration of these facts:

(ii) B's subsequent sale of L1 stock is not taken into account for purposes of determining whether

the L loss group has an ownership change under paragraph (b)(1)(i) of this section, and, accordingly, there is no ownership change of the L loss group. See paragraph (c) of this section, however, for a supplemental ownership change method that would apply to cause an ownership change if the purchases by C and D were pursuant to a plan or arrangement and certain other conditions are satisfied.

Example 3. Loss subgroup—ownership change of loss subgroup parent controls. (i) P owns all the L stock. L owns 80 percent and A owns 20 percent of the L1 stock. The P group has a consolidated net operating loss arising in Year 1 that is carried over to Year 2. On September 9, Year 2, P sells 51 percent of the L stock to B, and L1 is apportioned a portion of the Year 1 consolidated net operating loss under §1.1502-21(b), which it carries over to its next taxable year. L and L1 file a consolidated return for their first taxable year ending after the sale to B. The following is a graphic illustration of these facts:

(ii) Under §1.1502-91(d)(1), L and L1 compose a loss subgroup on September 9, Year 2, the day that they become members of the L group. Under paragraph (b)(1)(ii) of this section, section 382 and the regulations thereunder are applied to L to determine whether it (and therefore the L loss subgroup) has an ownership change with respect to the portion of the Year 1 consolidated net operating loss that is apportioned to L1 on September 9, Year 2. L has an ownership change resulting from P's sale of 51 percent of the L stock to A. Therefore, the L loss subgroup has an ownership change with respect to that loss.

Example 4. Loss group and loss subgroup—contemporaneous ownership changes. (i) A owns all the stock of corporation M, M owns 35 percent and B owns 65 percent of the L stock, and L owns all the L1 stock. The L group has a consolidated net operating loss arising in Year 1 that is carried over to Year 2. On May 19, Year 2, B sells 45 percent of the L stock to M for cash. M, L, and L1 thereafter file consolidated returns. L and L1 are each apportioned a portion of the Year 1 consolidated net operating

loss, which they carry over to the M group's Year 2 and Year 3 consolidated return years. The M group has a consolidated net operating loss arising in Year 2 that is carried over to Year 3. On June 9, Year 3, A sells 70 percent of the M stock to C. The following is a graphic illustration of these facts:

(ii) Under §1.1502-91(d)(1), L and L1 compose a loss subgroup on May 19, Year 2, the day they become members of the M group. Under paragraph (b)(1)(ii) of this section, section 382 and the regulations thereunder are applied to L to determine whether L (and therefore the L loss subgroup) has an ownership change with respect to the loss carryovers from Year 1 on May 19, Year 2, a testing date because of B's sale of L stock to M. The sale of L stock to M results in only a 45 percentage point increase in A's ownership of L stock. Thus, there is no ownership change of L (or the L loss subgroup) with respect to those loss carryovers under paragraph (b)(1)(ii) of this section on that day.

(iii) June 9, Year 3, is also a testing date with respect to the L loss subgroup because of A's sale of M stock to C. The sale results in a 56 percentage point increase in C's ownership of L stock, and L has an ownership change. Therefore, the L loss subgroup has an ownership change on that day with respect to the loss carryovers from Year 1.

(iv) Paragraph (b)(1)(i) of this section requires that section 382 and the regulations thereunder be applied to M to determine whether M (and therefore the M loss group) has an ownership change with respect to the net operating loss carryover from Year 2 on June 9, Year 3, a testing date because of A's sale of M stock to C. The sale results in a 70 percentage point increase in C's ownership of M stock, and M has an ownership change. Therefore, the M loss group has an ownership change on that day with respect to that loss carryover.

Example 5—Deemed subgroup parent. (i) P owns all the stock of L and L1 and 80 percent of the stock of T. A owns the remaining 20 percent of the stock of T. L1 owns all the stock of L2. P1, which owns 60 percent of the stock of P, acquires, at the beginning of Year 2, the T, L, and L1 stock owned by P, and T, L, L1, and L2 become members of the P1 group. The P group has a consolidated net operating loss arising in Year 1 that is carried over to Year 2. L, L1, and L2 are each apportioned a portion of the Year 1 consolidated net operating loss under §1.1502-21(b), which they carry over to the P1 group's Year 2 and Year 3 consolidated return years. P1 makes the election described in §1.1502-91(d)(4) to treat T, L, L1 and L2 as meeting the section 1504(a)(1) requirement of §1.1502-91(d)(1)(ii). As a result of the election, T, L, L1 and L2 compose a loss subgroup and T, L, L1, and L2 are each treated as the loss subgroup parent for purposes of this paragraph (b). Because of P1's indirect ownership of T, L, L1, and L2 prior to P1's acquisition of the T, L, and L1 stock, P1's acquisition does not cause an ownership change of the loss subgroup.

(ii) On February 2, Year 3, L1 sells all of the stock of L2 to B. Although L2 is treated as a loss subgroup parent, the determination whether the loss subgroup comprised of T, L, and L1 has an ownership change under this paragraph (b) is made without regard to the sale of L2 because L2's ownership change occurred upon ceasing to be a member of the P1 group. See §1.1502-95(b) to determine the ap-

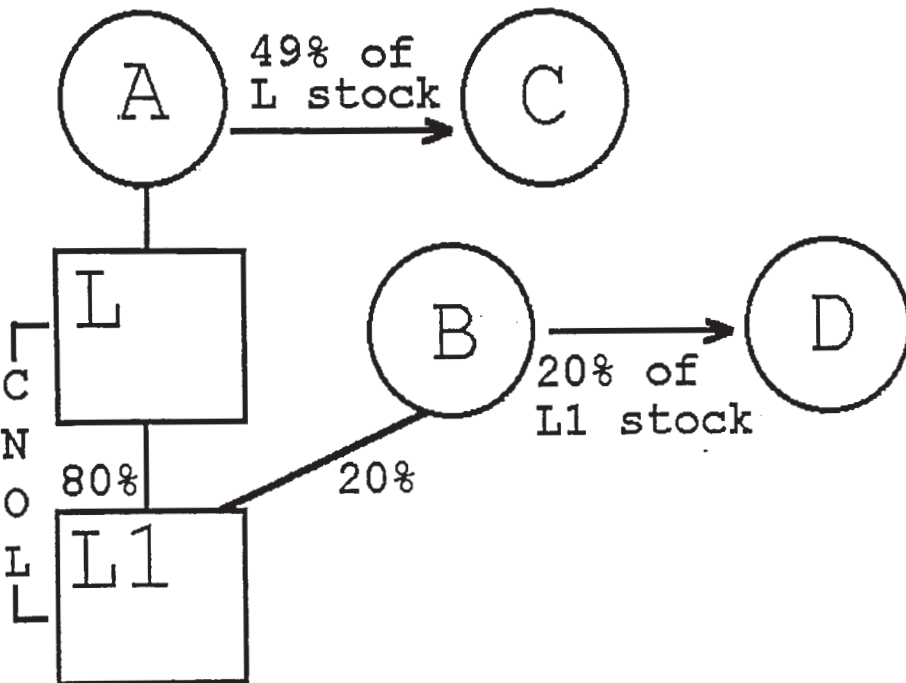

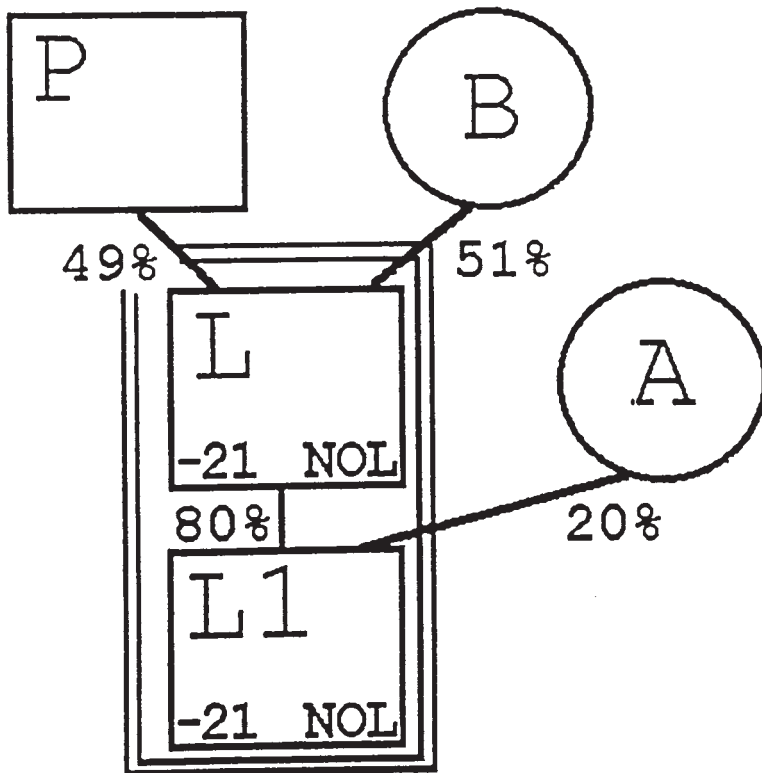
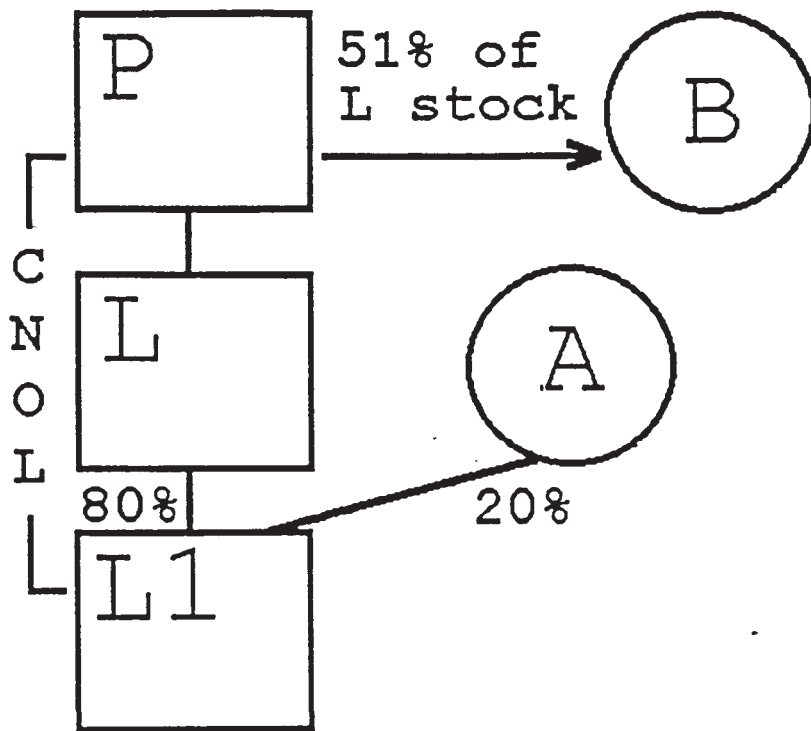

plication of section 382 to L2 when L2 ceases to be a member of the P1 group and the T, L, L1 and L2 loss subgroup.

(iii) On March 26, Year 3, A sells her 20 percent minority stock interest in T to C. C's purchase, to-

gether with the 32 percentage point owner shift effected by P1's acquisition of the T stock at the beginning of Year 2, causes an ownership change of T, and therefore of the loss subgroup comprised of T, L, and L1.

(3) *Special adjustments*—(i) Common parent succeeded by a new common parent. For purposes of determining if a loss group has an ownership change, if the common parent of a loss group is succeeded or acquired by a new common parent and the loss group remains in existence, the new common parent is treated as a continuation of the former common parent with appropriate adjustments to take into account shifts in ownership of the former common parent during the testing period (including shifts that occur incident to the common parent's becoming the former common parent). A new common parent may be a continuation of the former common parent even if, under §1.1502-91(g)(2)(ii), the new common parent is not included in determining whether the group has a net unrealized built-in loss.

(ii) *Newly created loss subgroup parent.* For purposes of determining if a loss subgroup has an ownership change, if the member that is the loss subgroup parent has not been the loss subgroup parent for at least 3 years as of a testing date, appropriate adjustments must be made to take into account owner shifts of members of the loss subgroup so that the structure of the loss subgroup does not have the effect of avoiding an ownership change under section 382. (See paragraph (b)(3)(iii), *Example 3* of this section.)

(iii) *Examples.* The following examples illustrate the principles of this paragraph (b)(3):

Example 1. New common parent acquires old common parent. (i) A, who owns all the L stock, sells 30 percent of the L stock to B on August 26, Year 1. L owns all the L1 stock. The L group has a consolidated net operating loss arising in Year 1 that is carried over to Year 3. On July 16, Year 2, A and B transfer their L stock to a newly created holding company, HC, in exchange for 70 percent and 30 percent, respectively, of the HC stock. HC, L, and L1 thereafter file consolidated returns. Under the principles of §1.1502-75(d), the L loss group is treated as remaining in existence, with HC taking the place of L as the new common parent of the loss group. The following is a graphic illustration of these facts:

(ii) On November 11, Year 3, A sells 25 percent of the HC stock to B. For purposes of determining if the L loss group has an ownership change under paragraph (b)(1)(i) of this section on November 11, Year 3, HC is treated as a continuation of L under paragraph (b)(4)(i) of this section because it acquired L and became the common parent without terminating the L loss group. Accordingly, HC's testing period commences on January 1, Year 1, the

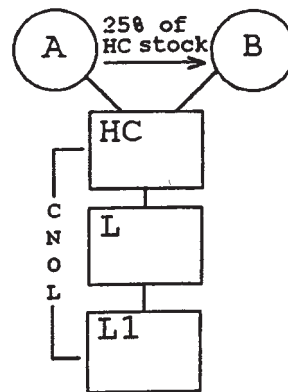
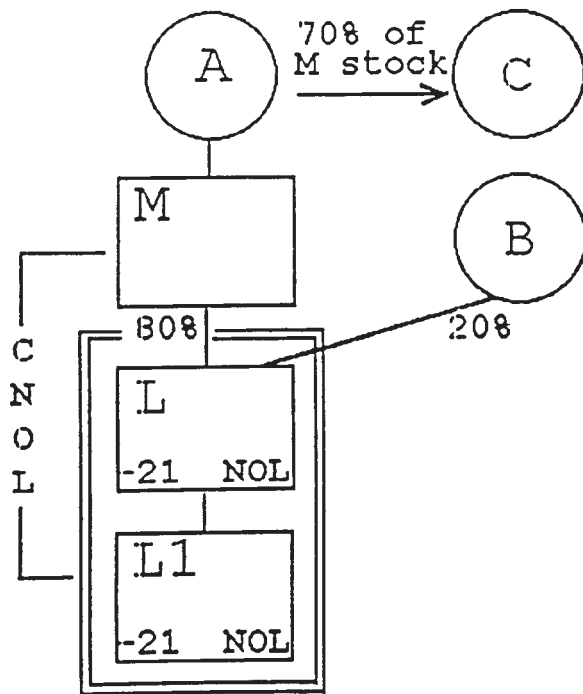
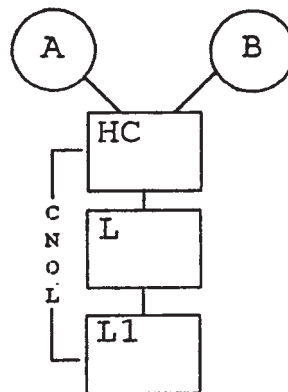
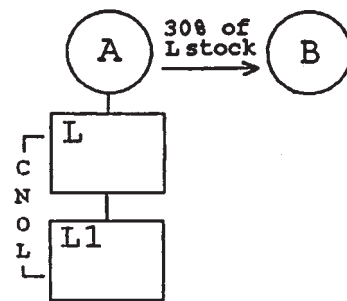
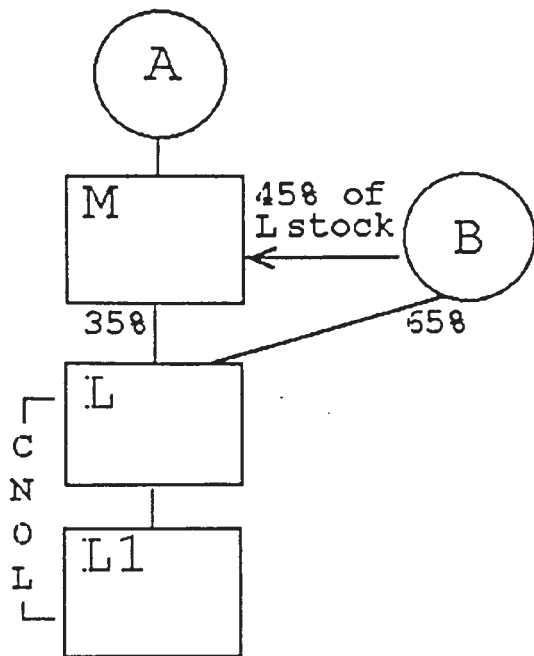

first day of the taxable year of the L loss group in which the consolidated net operating loss that is carried over to Year 3 arose (see §1.382-2T(d)(3)(i)). Immediately after the close of November 11, Year 3, B's percentage ownership interest in the common parent of the loss group (HC) has increased by 55 percentage points over its lowest percentage ownership during the testing period (zero percent). Accordingly, HC and the L loss group have an ownership change on that day.

Example 2. New common parent in case in which common parent ceases to exist. (i) A, B, and C each own one-third of the L stock. L owns all the L1 stock. The L group has a consolidated net operating loss arising in Year 2 that is carried over to Year 3. On November 22, Year 3, L is merged into P, a corporation owned by D, and L1 thereafter files consolidated returns with P. A, B, and C, as a result of owning stock of L, own 90 percent of P's stock after the merger. D owns the remaining 10 percent of P's

stock. The merger of L into P qualifies as a reverse acquisition of the L group under §1.1502-75(d)(3)(i), and the L loss group is treated as remaining in existence, with P taking the place of L as the new common parent of the L group. The following is a graphic illustration of these facts:

(ii) For purposes of determining if the L loss group has an ownership change on November 22, Year 3, the day of the merger, P is treated as a continuation of L so that the testing period for P begins on January 1, Year 2, the first day of the taxable year of the L loss group in which the consolidated net operating loss that is carried over to Year 3 arose. Immediately after the close of November 22, Year 3, D is the only 5-percent shareholder that has increased his ownership interest in P during the testing period (from zero to 10 percentage points).

(iii) The facts are the same as in paragraph (i) of this Example 2, except that A has held 23 1/3 shares (23 1/3 percent) of L's stock for five years, and A purchased an additional 10 shares of L stock from E

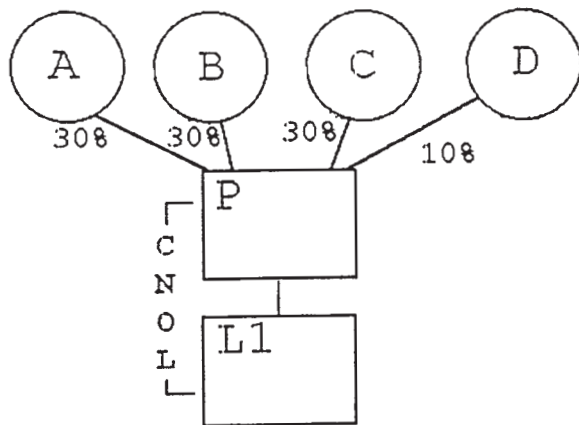
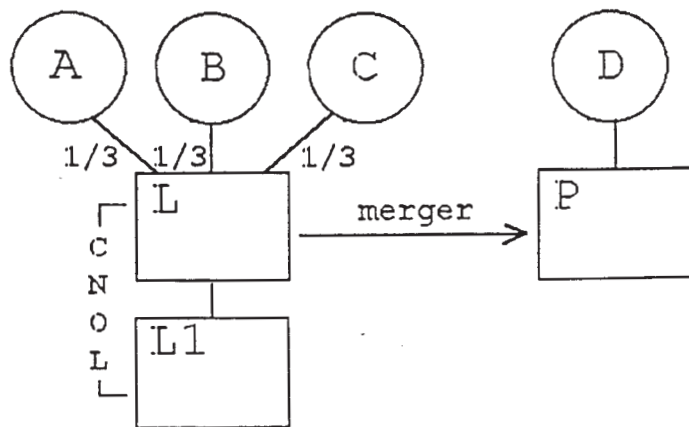

two years before the merger. Immediately after the close of the day of the merger (a testing date), A's ownership interest in P, the common parent of the L loss group, has increased by 6 2/3 percentage points over A's lowest percentage ownership during the testing period (23 1/3 percent to 30 percent).

(iv) The facts are the same as in (i) of this Example 2, except that P has a net operating loss arising in Year 1 that is carried to the first consolidated return year ending after the day of the merger. Solely for purposes of determining whether the L loss group has an ownership change under paragraph (b)(1)(i) of this section, the testing period for P commences on January 1, Year 2. P does not determine the earliest day for its testing period by reference to its net operating loss carryover from Year 1, which §§1.1502-1(f)(3) and 1.1502-75(d)(3)(i) treat as arising in a SRLY. See §1.1502-94 to determine the application of section 382 with respect to P's net operating loss carryover.

Example 3. Newly acquired loss subgroup parent. (i) P owns all the L stock and L owns all the L1 stock. The P group has a consolidated net operating loss arising in Year 1 that is carried over to Year 3. On January 19, Year 2, L issues a 20 percent stock interest to B. On February 5, Year 3, P contributes its L stock to a newly formed subsidiary, HC, in ex-

change for all the HC stock, and distributes the HC stock to its sole shareholder A. HC, L, and L1 thereafter file consolidated returns. A portion of the P group's Year 1 consolidated net operating loss is apportioned to L and L1 under §1.1502-21(b) and is carried over to the HC group's year ending after February 5, Year 3. HC, L, and L1 compose a loss subgroup within the meaning of §1.1502-91(d) with respect to the net operating loss carryovers from Year 1. The following is a graphic illustration of these facts:

(ii) February 5, Year 3, is a testing date for HC as the loss subgroup parent with respect to the net operating loss carryovers of L and L1 from Year 1. See paragraph (b)(1)(ii)(B) of this section. For purposes of determining whether HC has an ownership change on the testing date, appropriate adjustments must be made with respect to the changes in the percentage ownership of the stock of HC because HC was not the loss subgroup parent for at least 3 years prior to the day on which it became a member of the HC loss subgroup (a testing date). The appropriate adjustments include adjustments so that HC succeeds to the owner shifts of other members of the former group. Thus, HC succeeds to the owner shift of L that resulted from the sale of the 20 percent interest to B in determining whether the HC loss sub-

group has an ownership change on February 5, Year 3, and on any subsequent testing date that includes January 19, Year 2.

(4) *End of separate tracking of certain losses.* If §1.1502-96(a) (relating to the end of separate tracking of attributes) applies to a loss subgroup, then, while one or more members that were included in the loss subgroup remain members of the consolidated group, there is an ownership change with respect to their attributes described in §1.1502-96(a)(2) only if the consolidated group is a loss group and has an ownership change under paragraph (b)(1)(i) of this section (or such a member has an ownership change under §1.1502-96(b) (relating to ownership changes of subsidiaries)). If, however, the loss subgroup has had an ownership change before §1.1502-96(a) applies, see §1.1502-96(c) for the continuing application of the subgroup's section 382 limitation with respect to its pre-change subgroup attributes.

(c) *Supplemental rules for determining ownership change—(1) Scope.* This paragraph (c) contains a supplemental rule for determining whether there is an ownership change of a loss group (or loss subgroup). It applies in addition to, and not instead of, the rules of paragraph (b) of this section. Thus, for example, if the common parent of the loss group has an ownership change under paragraph (b) of this section, the loss group has an ownership change even if, by applying this paragraph (c), the common parent would not have an ownership change. This paragraph (c) does not apply in determining an ownership change of a loss subgroup for which an election under §1.1502-1(d)(4) is made.

(2) *Cause for applying supplemental rule.* This paragraph (c) applies to a loss group (or loss subgroup) if—

(i) Any 5-percent shareholder of the common parent (or loss subgroup parent) increases its percentage ownership interest in the stock of both—

(A) A subsidiary of the loss group (or loss subgroup) other than by a direct or indirect acquisition of stock of the common parent (or loss subgroup parent); and

(B) The common parent (or loss subgroup parent);

(ii) Those increases occur within a 3 year period ending on any day of a consolidated return year or, if shorter, the pe-

riod beginning on the first day following the most recent ownership change of the loss group (or loss subgroup); and

(iii) Either—

(A) The common parent (or loss subgroup parent) has actual knowledge of the increase in the 5-percent shareholder's ownership interest in the stock of the subsidiary (or has actual knowledge of the plan or arrangement described in paragraph (c) (3)(i) of this section) before the date that the group's income tax return is filed for the taxable year that includes the date of that increase; or

(B) At any time during the period described in paragraph (c)(2)(ii) of this section, the 5-percent shareholder of the common parent is also a 5-percent shareholder of the subsidiary (determined without regard to paragraph (c)(3)(i) of this section) whose percentage increase in the ownership of the stock of the subsidiary would be taken into account in determining if the subsidiary has an ownership change (determined as if the subsidiary was a loss corporation and applying the principles of §1.382-2T(k), including the principles relating to duty to inquire).

(3) *Operating rules.* Solely for purposes of this paragraph (c)—

(i) A 5-percent shareholder of the common parent (or loss subgroup parent) is treated as increasing its ownership interest in the stock of a subsidiary to the extent, if any, that another person or persons increases its percentage ownership interest in the stock of a subsidiary pursuant to a plan or arrangement under which the 5-percent shareholder increases its percentage ownership interest in the common parent (or loss subgroup parent);

(ii) The rules in section 382(l)(3) and §§1.382-2T(h) and 1.382-4(d) (relating to constructive ownership) apply with respect to the stock of the subsidiary by treating such stock as stock of a loss corporation; and

(iii) In the case of a loss subgroup, a subsidiary includes any member of the loss subgroup other than the loss subgroup parent. (A loss subgroup parent is, however, a subsidiary of the loss group of which it is a member.)

(4) *Supplemental ownership change rules.* The determination whether the common parent (or loss subgroup parent) has an ownership change is made by applying paragraph (b)(1) of this section as

modified by the following additional rules:

(i) *Additional testing dates for the common parent (or loss subgroup parent).*

A testing date for the common parent (or loss subgroup parent) also includes—

(A) Each day on which there is an increase in the percentage ownership of stock of a subsidiary as described in paragraph (c)(2) of this section; and

(B) The first day of the first consolidated return year for which the group is a loss group (or the members compose a loss subgroup).

(ii) *Treatment of subsidiary stock as stock of the common parent (or loss subgroup parent).* The common parent (or loss subgroup parent) is treated as though it had issued to the person acquiring (or deemed to acquire) the subsidiary stock an amount of its own stock (by value) that equals the value of the subsidiary stock represented by the percentage increase in that person's ownership of the subsidiary (determined on a separate entity basis). Similar principles apply if the increase in percentage ownership interest is effected by a redemption or similar transaction.

(iii) *Different testing periods.* Stock treated as issued under paragraph (c)(4)(ii) of this section on a testing date is not treated as so issued for purposes of applying the ownership change rules of this paragraph (c) and paragraph (b) (1) of this section in a testing period that does not include that testing date.

(iv) *Disaffiliation of a subsidiary.* If a deemed issuance of stock under paragraph (c)(4)(ii) of this section would not cause the loss group (or loss subgroup) to have an ownership change before the day (if any) on which the subsidiary ceases to be a member of the loss group (or subgroup), then paragraph (c)(4) of this section shall not apply.

(v) *Subsidiary stock acquired first.* If an increase of subsidiary stock described in paragraph (c)(2)(i)(A) of this section occurs before the date that the 5-percent shareholder increases its percentage ownership interest in the stock of the common parent (or loss subgroup parent), then the deemed issuance of stock is treated as occurring on that later date, but in an amount equal to the value of the subsidiary stock on the date it was acquired.

(vi) *Anti-duplication rule.* If two or more 5-percent shareholders are treated as

increasing their percentage ownership interests pursuant to the same plan or arrangement described in paragraph (c)(3)(i) of this section, appropriate adjustments must be made so that the amount of stock treated as issued is not taken into account more than once.

(5) *Examples.* The following examples illustrate the principles of this paragraph (c):

Example 1. Stock of the common parent under supplemental rules. (i) A owns all the L stock. L is not a member of an affiliated group and has a net operating loss carryover arising in Year 1 that is carried over to Year 6. On September 20, Year 6, L transfers all of its assets and liabilities to a newly created subsidiary, S, in exchange for S stock. L and S thereafter file consolidated returns. On November 23, Year 6, B contributes cash to L in exchange for a 45 percent ownership interest in L and contributes cash to S for a 20 percent ownership interest in S.

(ii) During the 3 year period ending on November 23, Year 6, B is a 5% shareholder of L and of S that increases its ownership interest in L and S during that period. Under paragraph (c)(4)(ii) of this section, the determination whether L (the common parent of a loss group) has an ownership change on November 23, Year 6 (or, subject to paragraph (c)(4)(iv) of this section, on any testing date in the testing period which includes November 23, Year 6), is made by applying paragraph (b)(1)(i) of this section and by treating the value of B's 20 percent ownership interest in S as if it were L stock issued to B. Because B is a 5% shareholder of both L and S during the 3 year period ending on November 23, Year 6, and B's increase in its percentage ownership in the stock of S would be taken into account in determining if S (if it were a loss corporation) had an ownership change, it is not relevant whether L has actual knowledge of B's acquisition of S stock.

Example 2. Plan or arrangement—public offering of subsidiary stock. (i) A owns all the stock of L and L owns all the stock of L1. The L group has a consolidated net operating loss arising in Year 1 that resulted from the operations of L1 and that is carried over to Year 2. On October 7, Year 2, A sells 49 percent of the L stock to B. As part of a plan that includes the sale of L stock, A causes a public offering of L1 stock on November 6, Year 2. L has actual knowledge of the plan. The following is a graphic illustration of these facts:

(ii) A's sale of the L stock to B does not cause an ownership change of the L loss group on October 7, Year 2, under the rules of §1.382-2T and paragraph (b)(1)(i) of this section.

(iii) Because the issuance of L1 stock to the public occurs as part of the same plan as B's acquisition of L stock, and L has knowledge of the plan, paragraph (c)(4) of this section applies to determine whether the L loss group has an ownership change on November 6, Year 2 (or, subject to paragraph (c)(4)(iv) of this section, on any testing date for which the testing period includes November 6, Year 2).

(d) *Testing period following ownership change under this section.* If a loss group (or a loss subgroup) has had an ownership

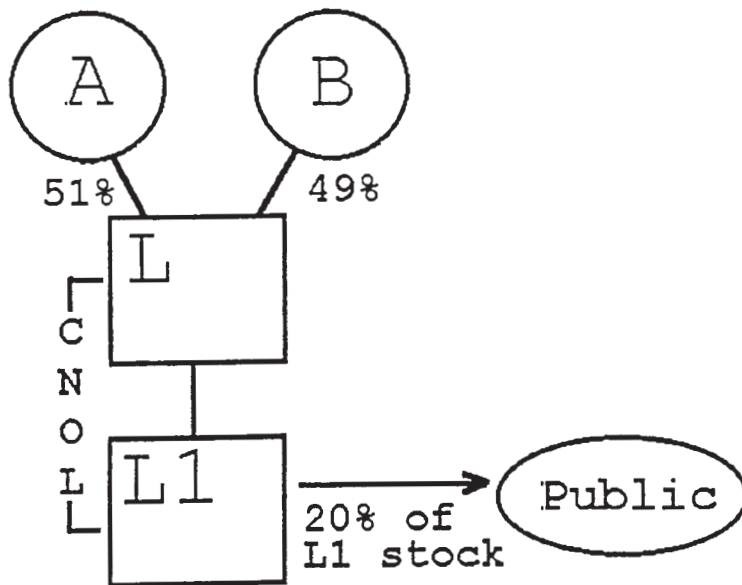
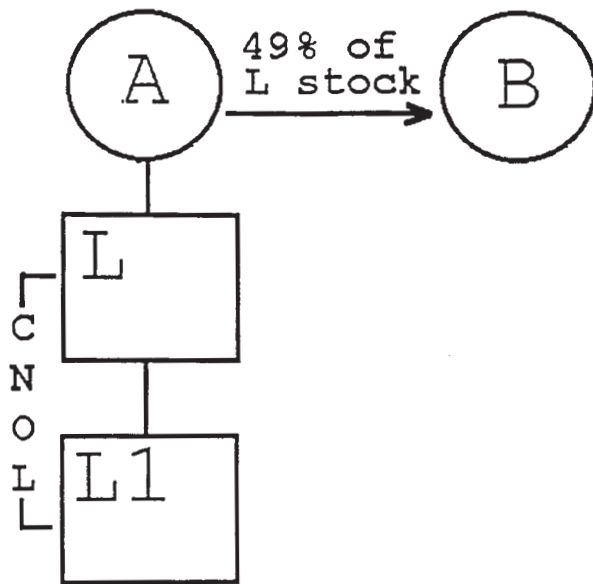

change under this section, the testing period for determining a subsequent ownership change with respect to pre-change consolidated attributes (or pre-change subgroup attributes) begins no earlier than the first day following the loss group's (or loss subgroup's) most recent change date.

(e) *Information statements*—(1) *Common parent of a loss group.* The common parent of a loss group must file the information statement required by §1.382-2T(a)(2)(ii) for a consolidated return year because of any owner shift, equity structure shift, or other transaction described in §1.382-2T(a)(2)(i)—

(i) With respect to the common parent and with respect to any subsidiary stock

subject to paragraph (c) of this section; and

(ii) With respect to an ownership change described in §1.1502-96(b) (relating to ownership changes of subsidiaries).

(2) *Abbreviated statement with respect to loss subgroups.* The common parent of a consolidated group that has a loss subgroup during a consolidated return year must file the information statement required by §1.382-2T(a)(2)(ii) because of any owner shift, equity structure shift, or other transaction described in §1.382-2T(a)(2)(i) with respect to the loss subgroup parent and with respect to any subsidiary stock subject to paragraph (c) of this section. Instead of filing a separate

statement for each loss subgroup parent, the common parent (which is treated as a loss corporation) may file the single statement described in paragraph (e)(1) of this section. In addition to the information concerning stock ownership of the common parent, the single statement must identify each loss subgroup parent and state which loss subgroups, if any, have had ownership changes during the consolidated return year. The loss subgroup parent is, however, still required to maintain the records necessary to determine if the loss subgroup has an ownership change. This paragraph (e)(2) applies with respect to the attributes of a loss subgroup until, under §1.1502-96(a), the attributes are no longer treated as described in §1.1502-91(d) (relating to the definition of loss subgroup). After that time, the information statement described in paragraph (e)(1) of this section must be filed with respect to those attributes.

§1.1502-93 *Consolidated section 382 limitation (or subgroup section 382 limitation).*

(a) *Determination of the consolidated section 382 limitation (or subgroup section 382 limitation)*—(1) *In general.* Following an ownership change, the consolidated section 382 limitation (or subgroup section 382 limitation) for any post-change year is an amount equal to the value of the loss group (or loss subgroup), as defined in paragraph (b) of this section, multiplied by the long-term tax-exempt rate that applies with respect to the ownership change, and adjusted as required by section 382 and the regulations thereunder. See, for example, section 382(b)(2) (relating to the carryforward of unused section 382 limitation), section 382(b)(3)(B) (relating to the section 382 limitation for the post-change year that includes the change date), section 382(h) (relating to recognized built-in gains and section 338 gains), and section 382(m)(2) (relating to short taxable years). For special rules relating to the recognized built-in gains of a loss group (or loss subgroup), see paragraph (c)(2) of this section.

(2) *Coordination with apportionment rule.* For special rules relating to apportionment of a consolidated section 382 limitation (or a subgroup section 382 limitation) or net unrealized built-in gain when one or more corporations cease to

be members of a loss group (or a loss subgroup) and to aggregation of amounts so apportioned, see §1.1502-95(c).

(b) *Value of the loss group (or loss subgroup)*—(1) *Stock value immediately before ownership change.* Subject to any adjustment under paragraph (b)(2) of this section, the value of the loss group (or loss subgroup) is the value, immediately before the ownership change, of the stock of each member, other than stock that is owned directly or indirectly by another member. For this purpose—

(i) Ownership is determined under §1.382-2T;

(ii) A member is considered to indirectly own stock of another member through a nonmember only if the member has a 5-percent or greater ownership interest in the nonmember; and

(iii) Stock includes stock described in section 1504(a)(4) and §1.382-2T(f)(18)(ii) and (iii).

(2) *Adjustment to value*—(i) *In general.* The value of the loss group (or loss subgroup), as determined under paragraph (b)(1) of this section, is adjusted under any rule in section 382 or the regulations thereunder requiring an adjustment to such value for purposes of computing the amount of the section 382 limitation. See, for example, section 382(e)(2) (redemptions and corporate contractions), section 382(l)(1) (certain capital contributions) and section 382(l)(4) (ownership of substantial non-business assets). For purposes of section 382(e)(2), redemptions and corporate contractions that do not effect a transfer of value outside of the loss group (or loss subgroup) are disregarded. For purposes of section 382(l)(1), capital contributions between members of the loss group (or loss subgroup) (or a contribution of stock to a member made solely to satisfy the loss subgroup parent requirement of paragraph (d)(1)(ii) or (2)(ii) of this section), are not taken into account. Also, the substantial nonbusiness asset test of section 382(l)(4) is applied on a group (or subgroup) basis, and is not applied separately to its members.

(ii) *Anti-duplication.* Appropriate adjustments must be made to the extent necessary to prevent any duplication of the value of the stock of a member, even though corporations that do not file consolidated returns may not be required to

make such an adjustment. In making these adjustments, the group (or loss subgroup) may apply the principles of §1.382-8 (relating to controlled groups of corporations) in determining the value of a loss group (or loss subgroup) even if that section would not apply if separate returns were filed. Also, the principles of §1.382-5(d) (relating to successive ownership changes and absorption of a section 382 limitation) may apply to adjust the consolidated section 382 limitation (or subgroup section 382 limitation) of a loss group (or loss subgroup) to avoid a duplication of value if there are simultaneous (rather than successive) ownership changes.

(3) *Examples.* The following examples illustrate the principles of this paragraph (b):

Example 1. Basic case. (i) L, L1, and L2 compose a loss group. L has outstanding common stock, the value of which is \$100. L1 has outstanding common stock and preferred stock that is described in section 1504(a)(4). L owns 90 percent of the L1 common stock, and A owns the remaining 10 percent of the L1 common stock plus all the preferred stock. The value of the L1 common stock is \$40, and the value of the L1 preferred stock is \$30. L2 has outstanding common stock, 50 percent of which is owned by L and 50 percent by L1. The L group has an ownership change. The following is a graphic illustration of these facts:

(ii) Under paragraph (b)(1) of this section, the L group does not include the value of the stock of any member that is owned directly or indirectly by another member in computing its consolidated section 382 limitation. Accordingly, the value of the stock of the loss group is \$134, the sum of the value of—

(a) The common stock of L (\$100);

(b) The 10 percent of the L1 common stock (\$4) owned by A; and

(c) The L1 preferred stock (\$30) owned by A.

Example 2—Indirect ownership. (i) L and L1 compose a consolidated group. L's stock has a value of \$100. L owns 80 shares (worth \$80) and corporation M owns 20 shares (worth \$20) of the L1 stock. L also owns 79 percent of the stock of corporation M. The L group has an ownership change. The following is a graphic illustration of these facts:

(ii) Under paragraph (b)(1) of this section, because of L's more than 5 percent ownership interest in M, a nonmember, L is considered to indirectly own 15.8 shares of the L1 stock held by M (79% x 20 shares). The value of the L loss group is \$104.20, the sum of the values of—

(a) The L stock (\$100); and

(b) The L1 stock not owned directly or indirectly by L (21% x \$20, or \$4.20).

(c) *Recognized built-in gain of a loss group or loss subgroup*—(1) *In general.* If a loss group (or loss subgroup) has a net unrealized built-in gain, any recognized built-in gain of the loss group (or loss subgroup) is taken into account under section 382(h) in determining the consolidated section 382 limitation (or subgroup section 382 limitation).

(2) *Adjustments.* Appropriate adjustments must be made so that any recognized built-in gain of a member that increases more than one section 382 limitation (whether consolidated, subgroup, or separate) does not effect a duplication in the amount of consolidated taxable income that can be offset by pre-change net operating losses. For example, a consolidated section 382 limitation that is increased by recognized built-in gains is reduced to the extent that pre-change net operating losses of a loss subgroup absorb additional consolidated taxable income because the same recog-

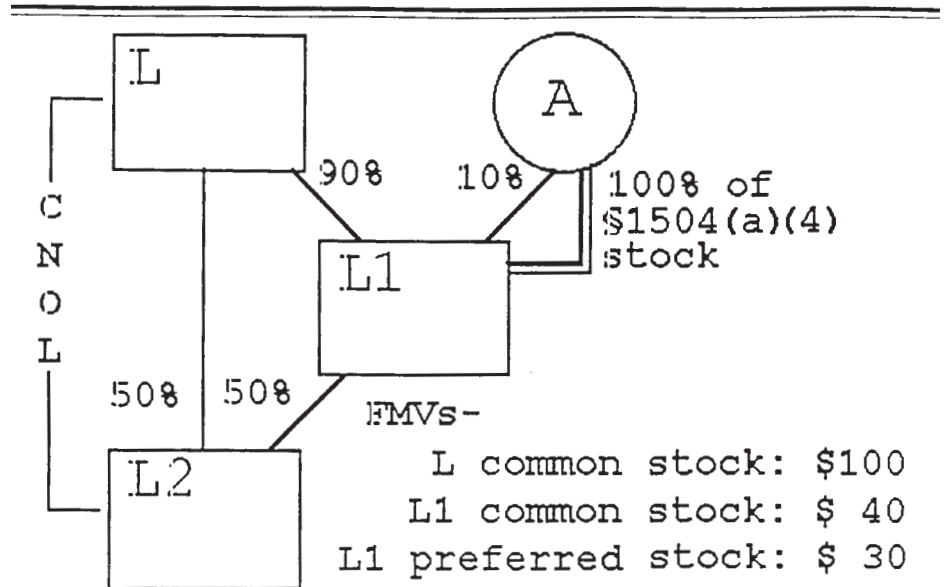

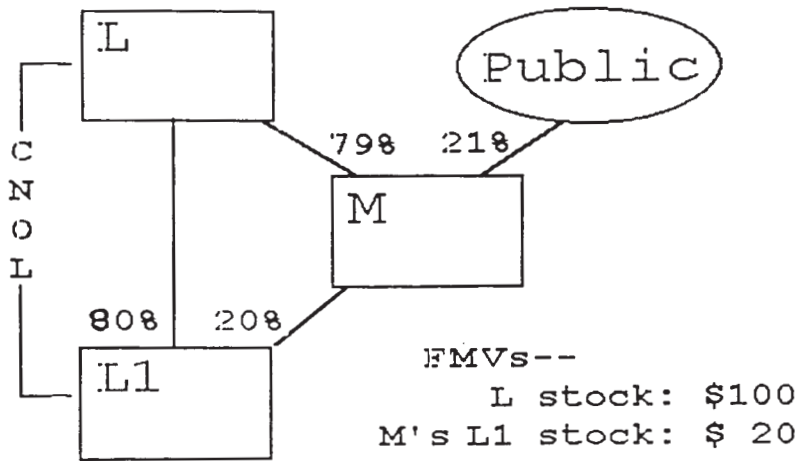

nized built-in gains caused an increase in that loss subgroup's section 382 limitation. In addition, recognized built-in gain may not increase the amount of consolidated taxable income that can be offset by recognized built-in losses.

(d) *Continuity of business*—(1) *In general.* A loss group (or a loss subgroup) is treated as a single entity for purposes of determining whether it satisfies the continuity of business enterprise requirement of section 382(c)(1).

(2) *Example.* The following example illustrates the principle of this paragraph (d):

Example. Continuity of business enterprise. L owns all the stock of two subsidiaries, L1 and L2. The L group has an ownership change. It has pre-change consolidated attributes attributable to L2. Each of the members has historically conducted a separate line of business. Each line of business is approximately equal in value. One year after the ownership change, L discontinues its separate business and the business of L2. The separate business of L1 is continued for the remainder of the 2 year period following the ownership change. The continuity of business enterprise requirement of section 382(c)(1) is met even though the separate businesses of L and L2 are discontinued.

(e) *Limitations of losses under other rules.* If a section 382 limitation for a post-change year exceeds the consolidated taxable income that may be offset by pre-change attributes for any reason, including the application of the limitation of §1.1502-21(c), the amount of the excess is carried forward under section 382(b)(2) (relating to the carryforward of unused section 382 limitation).

§1.1502-94 *Coordination with section 382 and the regulations thereunder when a corporation becomes a member of a consolidated group.*

(a) *Scope*—(1) *In general.* This section applies section 382 and the regulations thereunder to a corporation that is a new loss member of a consolidated group. A corporation is a new loss member if it—

(i) Carries over a net operating loss that arose (or is treated under §1.1502-21(c) as arising) in a SRLY with respect to the current group, and that is not described in §1.1502-91(d)(1); or

(ii) Has a net unrealized built-in loss (determined under paragraph (c) of this section immediately before it becomes a member of the current group by treating that day as a change date) that is not taken into account under §1.1502-91(d)(2) in determining whether two or more corporations compose a loss subgroup.

(2) *Successor corporation as new loss member.* A new loss member also includes any successor to a corporation that has a net operating loss carryover arising in a SRLY and that is treated as remaining in existence under §1.382-2(a)(1)(ii) following a transaction described in section 381(a).

(3) *Coordination in the case of a loss subgroup.* For rules regarding the determination of whether there is an ownership change of a loss subgroup with respect to a net operating loss or a net unrealized built-in loss described in §1.1502-91(d)

(relating to the definition of loss subgroup) and the computation of a subgroup section 382 limitation following such an ownership change, see §§1.1502-92 and 1.1502-93.

(4) *End of separate tracking of certain losses.* If §1.1502-96(a) (relating to the end of separate tracking of attributes) applies to a new loss member, then, while that member remains a member of the consolidated group, there is an ownership change with respect to its attributes described in §1.1502-96(a)(2) only if the consolidated group is a loss group and has an ownership change under §1.1502-92(b)(1)(i) (or that member has an ownership change under §1.1502-96(b) (relating to ownership changes of subsidiaries)). If, however, the new loss member has had an ownership change before §1.1502-96(a) applies, see §1.1502-96(c) for the continuing application of the section 382 limitation with respect to the member's pre-change losses.

(5) *Cross-reference.* See section 382(a) and §1.1502-96(c) for the continuing effect of an ownership change after a corporation becomes or ceases to be a member.

(b) *Application of section 382 to a new loss member*—(1) *In general.* Section 382 and the regulations thereunder apply to a new loss member to determine, on a separate entity basis, whether and to what extent a section 382 limitation applies to limit the amount of consolidated taxable income that may be offset by the new loss member's pre-change separate attributes. For example, if an ownership change with respect to the new loss member occurs under section 382 and the regulations thereunder, the amount of consolidated taxable income for any post-change year that may be offset by the new loss member's pre-change separate attributes shall not exceed the section 382 limitation as determined separately under section 382(b) with respect to that member for such year. If the post-change year includes the change date, section 382(b)-(3)(A) is applied so that the section 382 limitation of the new loss member does not apply to the portion of the taxable income for such year that is allocable to the

period in such year on or before the change date. See generally §1.382-6 (relating to the allocation of income and loss).

(2) *Adjustment to value.* Appropriate adjustments must be made to the extent necessary to prevent any duplication of the value of the stock of a member, even though corporations that do not file consolidated returns may not be required to make such an adjustment. For example, the principles of §1.1502-93(b)(2)(ii) (relating to adjustments to value) apply in determining the value of a new loss member.

(3) *Pre-change separate attribute defined.* A pre-change separate attribute of a new loss member is—

(i) Any net operating loss carryover of the new loss member described in paragraph (a)(1) of this section; and

(ii) Any recognized built-in loss of the new loss member.

(4) *Examples.* The following examples illustrate the principles of this paragraph (b):

Example 1. Basic case. (i) A and P each own 50 percent of the L stock. On December 19, Year 6, P purchases 30 percent of the L stock from A for cash. L has net operating losses arising in Year 1 and Year 2 that it carries over to Year 6 and Year 7. The following is a graphic illustration of these facts:

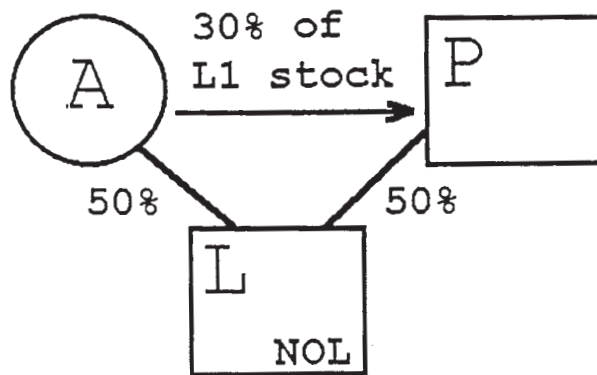

(ii) L is a new loss member because it has net operating loss carryovers that arose in a SRLY with respect to the P group and L is not a member of a loss subgroup under §1.1502-91(d). Under section 382 and the regulations thereunder, L is a loss corporation on December 19, Year 6, that day is a testing date for L, and the testing period for L commences on December 20, Year 3.

(iii) P's purchase of L stock does not cause an ownership change of L on December 19, Year 6, with respect to the net operating loss carryovers from Year 1 and Year 2 under section 382 and §1.382-2T. The use of the loss carryovers, however, is subject to limitation under §1.1502-21(c).

Example 2. Multiple new loss members. (i) The facts are the same as in Example 1, and, on December 31, Year 6, L purchases all the stock of L1 from B for cash. L1 has a net operating loss of \$40 arising in Year 3 that it carries over to Year 7. The following is a graphic illustration of these facts:

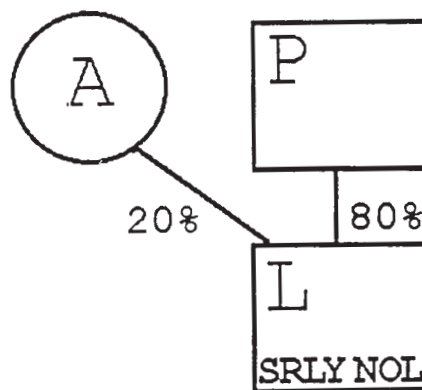

(ii) L1 is a new loss member because it has a net operating loss carryover from Year 3 that arose in a SRLY with respect to the P group and L1 is not a member of a loss subgroup under §1.1502-91(d)(1).

(iii) L's purchase of all the stock of L1 causes an ownership change of L1 on December 31, Year 6, under section 382 and §1.382-2T. Accordingly, a section 382 limitation based on the value of the L1 stock immediately before the ownership change limits the amount of consolidated taxable income of the P group for any post-change year that may be offset by L1's loss from Year 3.

(iv) L1's ownership change upon becoming a member of the P group is an ownership change described in §1.1502-96(a). Thus, starting on January 1, Year 7, the P group no longer separately tracks owner shifts of the stock of L1 with respect to L1's loss from Year 3, and the P group is a loss group because L1's Year 3 loss is treated as a loss described in §1.1502-91(c).

Example 3. Ownership changes of new loss members. (i) The facts are the same as in Example 2, and, on July 30, Year 7, C purchases all the stock of P for cash.

(ii) L is a new loss member on July 30, Year 7, because its Year 1 and Year 2 losses arose in SRLYs with respect to the P group and it is not a member of a loss subgroup under §1.1502-91(d)(1). The testing period for L commences on August 1, Year 4. C's purchase of all the P stock causes an ownership change of L on July 30, Year 7, under section 382 and §1.382-2T with respect to its Year 1 and Year 2 losses. Accordingly, a section 382 limitation based on the value of the L stock immediately before the ownership change limits the amount of consolidated taxable income of the P group for any post-change year that may be offset by L's Year 1 and Year 2 losses. See §1.1502-21(c) for rules relating to an additional limitation.

(iii) The P group is a loss group on July 30, Year 7, because it is entitled to use L1's loss from Year 3, and such loss is no longer treated as a loss of a new loss member starting the day after L1's ownership

change on December 31, Year 6. See §§1.1502-96(a) and 1.1502-91(c)(2). C's purchase of all the P stock causes an ownership change of P, and therefore the P loss group, on July 30, Year 7, with respect to L1's Year 3 loss. Accordingly, a consolidated section 382 limitation based on the value of the P stock immediately before the ownership change limits the amount of consolidated taxable income of the P group for any post-change year that may be offset by L1's Year 3 loss.

(c) *Built-in gains and losses.* As the context may require, the principles of §§1.1502-91(g) and (h) and 1.1502-93(c) (relating to built-in gains and losses) apply to a new loss member on a separate entity basis. See §1.1502-91(g)(4). See §1.1502-13 (including Example 10 of §1.1502-13(c)(7)) for rules relating to the treatment of intercompany transactions.

(d) *Information statements.* The common parent of a consolidated group that has a new loss member subject to paragraph (b)(1) of this section during a consolidated return year must file the information statement required by §1.382-2T(a)(2)(ii) because of any owner shift, equity structure shift, or other trans-

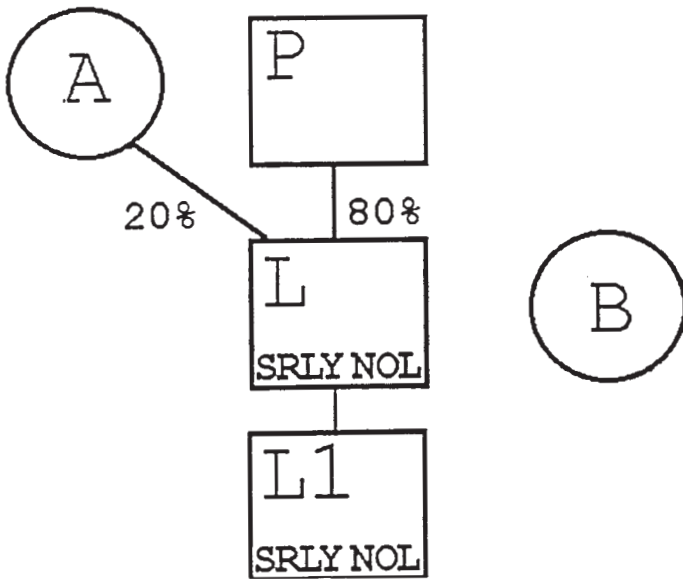
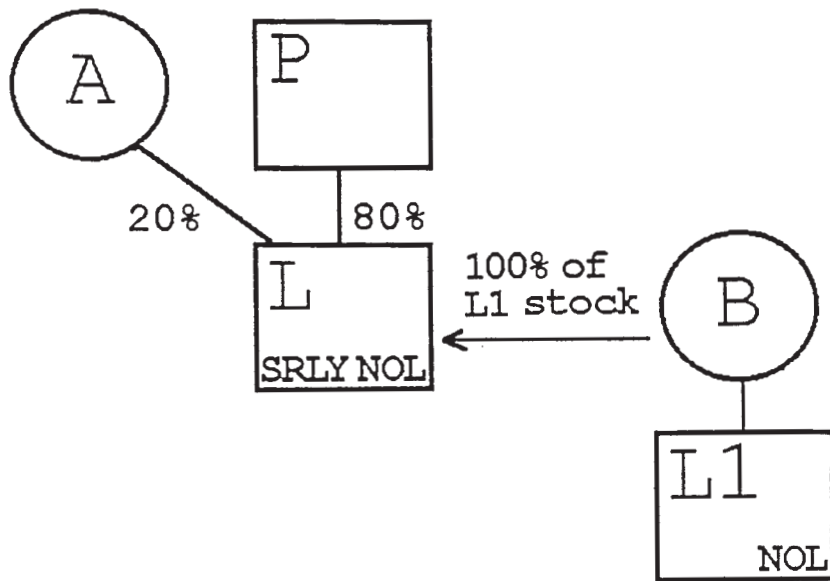

action described in §1.382-2T(a)(2)(i). Instead of filing a separate statement for each new loss member, the common parent may file a single statement described in §1.382-2T(a)(2)(ii) with respect to the stock ownership of the common parent (which is treated as a loss corporation). In addition to the information concerning stock ownership of the common parent, the single statement must identify each new loss member and state which new loss members, if any, have had ownership changes during the consolidated return year. The new loss member is, however, required to maintain the records necessary to determine if it has an ownership

change. This paragraph (d) applies with respect to the attributes of a new loss member until an event occurs which ends separate tracking under §1.1502-96(a). After that time, the information statement described in §1.1502-92(e)(1) must be filed with respect to these attributes.

§1.1502-95 Rules on ceasing to be a member of a consolidated group (or loss subgroup).

(a) *In general*—(1) *Consolidated group.* This section provides rules for applying section 382 on or after the day that a member ceases to be a member of a con-

solidated group (or loss subgroup). The rules concern how to determine whether an ownership change occurs with respect to losses of the member, and how a consolidated section 382 limitation (or subgroup section 382 limitation) and a loss group's (or loss subgroup's) net unrealized built-in gain or loss is apportioned to the member. As the context requires, a reference in this section to a loss group, a member, or a corporation also includes a reference to a loss subgroup, and a reference to a consolidated section 382 limitation also includes a reference to a subgroup section 382 limitation.

(2) *Election by common parent.* Only the common parent (not the loss subgroup parent) may make the election under paragraph (c) of this section to apportion a consolidated section 382 limitation (or subgroup section 382 limitation) or a loss group's (or loss subgroup's) net unrealized built-in gain.

(3) *Coordination with §§1.1502-91 through 1.1502-93.* For rules regarding the determination of whether there is an ownership change of a loss subgroup and the computation of a subgroup section 382 limitation following such an ownership change, see §§1.1502-91 through 1.1502-93.

(b) *Separate application of section 382 when a member leaves a consolidated group*—(1) *In general.* Except as provided in §§1.1502-91 through 1.1502-93 (relating to rules applicable to loss groups and loss subgroups), section 382 and the regulations thereunder apply to a corporation on a separate entity basis after it ceases to be a member of a consolidated group (or loss subgroup). Solely for purposes of determining whether a corporation has an ownership change—

(i) Any portion of a consolidated net operating loss that is apportioned to the corporation under §1.1502-21(b) is treated as a net operating loss of the corporation beginning on the first day of the taxable year in which the loss arose;

(ii) The testing period may include the period during which (or before which) the corporation was a member of the group (or loss subgroup); and

(iii) Except to the extent provided in §1.1502-96(d) (relating to reattributed losses), the day it ceases to be a member of a consolidated group is treated as a

testing date of the corporation within the meaning of §1.382-2(a)(4).

(2) *Effect of a prior ownership change of the group.* If a loss group has had an ownership change under §1.1502-92 before a corporation ceases to be a member of a consolidated group (the former member)—

(i) Any pre-change consolidated attribute that is subject to a consolidated section 382 limitation continues to be treated as a pre-change loss with respect to the former member after it is apportioned to the former member and, if any net unrealized built-in loss is allocated to the former member under paragraph (e) of this section, any recognized built-in loss of the former member is a pre-change loss of the member;

(ii) The section 382 limitation with respect to such pre-change attribute is zero unless the common parent, under paragraph (c) of this section, apportions to the former member all or part of the consolidated section 382 limitation applicable to such attribute. The limitation applicable to a pre-change attribute other than a recognized built-in loss may be increased to the extent that the common parent has apportioned all or part of the loss group's net unrealized built-in gain to the former member, and the former member recognizes built-in gain during the recognition period;

(iii) The testing period for determining a subsequent ownership change with respect to such pre-change attribute (or such net unrealized built-in loss, if any) begins no earlier than the first day following the loss group's most recent change date; and

(iv) As generally provided under section 382, an ownership change of the former member that occurs on or after the day it ceases to be a member of a loss group may result in an additional, lesser limitation amount with respect to such losses.

(3) *Application in the case of a loss subgroup.* If two or more former members are included in the same loss subgroup immediately after they cease to be members of a consolidated group, the principles of paragraphs (b), (c) and (e) of this section apply to the loss subgroup. Therefore, for example, an apportionment by the common parent under paragraph (c) of this section is made to the loss subgroup rather than separately to its mem-

bers. If the common parent of the consolidated group apportions all or part of a limitation (or net unrealized built-in gain) separately to one or more former members that are included in a loss subgroup because the common parent of the acquiring group makes an election under §1.1502-91(d)(4) with respect to those members, the aggregate of those separate amounts is treated as the amount apportioned to the loss subgroup. Such separate apportionment may occur, for example, because the election under §1.1502-91(d)(4) has not been filed at the time that the election of apportionment is made under paragraph (f) of this section.

(4) *Examples.* The following examples illustrate the principles of this paragraph (b):

Example 1. Treatment of departing member as a separate corporation throughout the testing period. (i) A owns all the L stock. L owns all the stock of L1 and L2. The L group has a consolidated net operating loss arising in Year 1 that is carried over to Year 3. On January 12, Year 2, A sells 30 percent of the L stock to B. On February 7, Year 3, L sells 40 percent of the L2 stock to C, and L2 ceases to be a member of the group. A portion of the Year 1 consolidated net operating loss is apportioned to L2 under §1.1502-21(b) and is carried to L2's first separate return year, which ends December 31, Year 3. The following is a graphic illustration of these facts:

(ii) Under paragraph (b)(1) of this section, L2 is a loss corporation on February 7, Year 3. Under

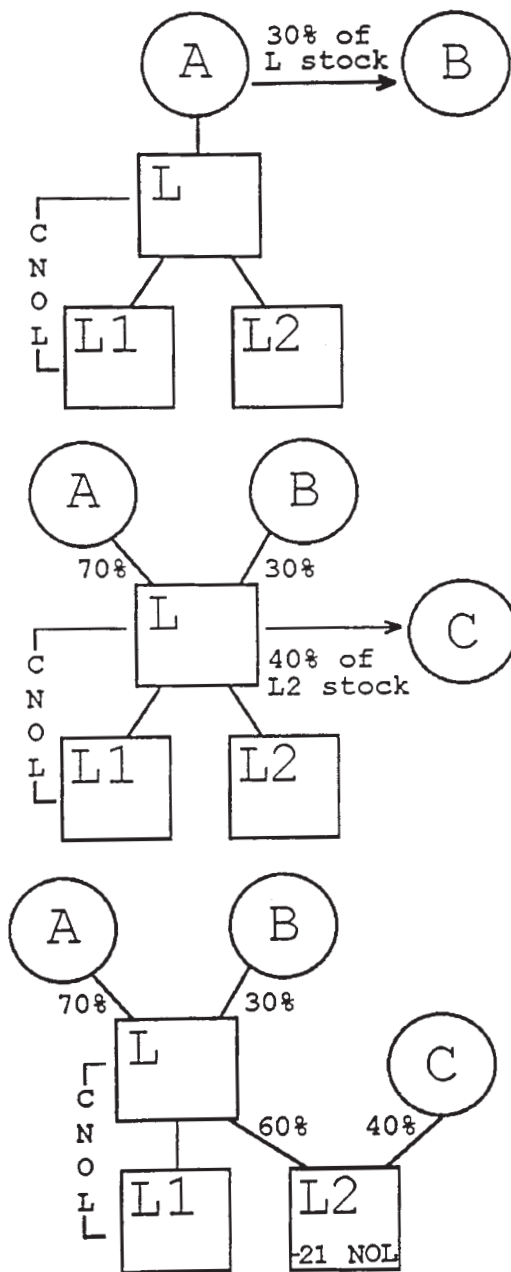

paragraph (b)(1)(iii) of this section, February 7, Year 3, is a testing date. Under paragraph (b)(1)(ii) of this section, the testing period for L2 with respect to this testing date commences on January 1, Year 1, the first day of the taxable year in which the portion of the consolidated net operating loss apportioned to L2 arose. Therefore, in determining whether L2 has an ownership change on February 7, Year 3, B's purchase of 30 percent of the L stock and C's purchase of 40 percent of the L2 stock are each owner shifts. L2 has an ownership change under section 382(g) and §1.382-2T because B and C have increased their ownership interests in L2 by 18 and 40 percentage points, respectively, during the testing period.

Example 2. Effect of prior ownership change of loss group. (i) L owns all the L1 stock and L1 owns all the L2 stock. The L loss group had an ownership change under §1.1502-92 in Year 2 with respect to a consolidated net operating loss arising in Year 1 and carried over to Year 2 and Year 3. The consolidated section 382 limitation computed solely on the basis of the value of the stock of L is \$100. On December 31, Year 2, L1 sells 25 percent of the stock of L2 to B. L2 is apportioned a portion of the Year 1 consolidated net operating loss which it carries over to its first separate return year ending after December 31, Year 2. L2's separate section 382 limitation with respect to this loss is zero unless L elects to apportion all or a part of the consolidated section 382 limitation to L2. (See paragraph (c) of this section for rules regarding the apportionment of a consolidated section 382 limitation.) L apportions \$50 of the consolidated section 382 limitation to L2, and the remaining \$50 of the consolidated section 382 limitation stays with the loss group composed of L and L1.

(ii) On December 31, Year 3, L1 sells its remaining 75 percent stock interest in L2 to C, resulting in an ownership change of L2. L2's section 382 limitation computed on the change date with respect to the value of its stock is \$30. Accordingly, L2's section 382 limitation for post-change years ending after December 31, Year 3, with respect to its pre-change losses, including the consolidated net operating losses apportioned to it from the L group, is \$30, adjusted for a short taxable year, carryforward of unused limitation, or any other adjustment required under section 382.

(c) *Apportionment of a consolidated section 382 limitation—(1) In general.* The common parent may elect to apportion all or any part of a consolidated section 382 limitation to a former member (or loss subgroup). The common parent also may elect to apportion all or any part of the loss group's net unrealized built-in gain to a former member (or loss subgroup).

(2) *Amount which may be apportioned—(i) Consolidated section 382 limitation.* The common parent may apportion all or part of each element of the consolidated section 382 limitation determined under §1.1502-93. For this purpose, the consolidated section 382 limitation consists of two elements—

(A) The value element, which is the element of the limitation determined under section 382(b)(1) (relating to value multiplied by the long-term tax-exempt rate) without regard to such adjustments as those described in section 382(b)(2) (relating to the carryforward of unused section 382 limitation), section 382(b)(3)-(B) (relating to the section 382 limitation for the post-change year that includes the change date), section 382(h) (relating to built-in gains and section 338 gains), and section 382(m)(2) (relating to short taxable years); and

(B) The adjustment element, which is so much (if any) of the limitation for the taxable year during which the former member ceases to be a member of the consolidated group that is attributable to a carryover of unused limitation under section 382(b)(2) or to recognized built-in gains under 382(h).

(ii) *Net unrealized built-in gain.* The aggregate amount of the loss group's net unrealized built-in gain that may be apportioned to one or more former members that cease to be members during the same consolidated return year cannot exceed the loss group's excess, immediately after the close of that year, of net unrealized built-in gain over recognized built-in gain, determined under section 382(h)(1)-(A)(ii) (relating to a limitation on recognized built-in gain). For this purpose, net unrealized built-in gain apportioned to former members in prior consolidated return years is treated as recognized built-in gain in those years.

(3) *Effect of apportionment on the consolidated group—(i) Consolidated section 382 limitation.* The value element of the consolidated section 382 limitation for any post-change year ending after the day that a former member (or loss subgroup) ceases to be a member(s) is reduced to the extent that it is apportioned under this paragraph (c). The consolidated section 382 limitation for the post-change year in which the former member (or loss subgroup) ceases to be a member(s) is also reduced to the extent that the adjustment element for that year is apportioned under this paragraph (c).

(ii) *Net unrealized built-in gain.* The amount of the loss group's net unrealized built-in gain that is apportioned to the former member (or loss subgroup) is treated as recognized built-in gain for a prior tax-

able year ending in the recognition period for purposes of applying the limitation of section 382(h)(1)(A)(ii) to the loss group's recognition period taxable years beginning after the consolidated return year in which the former member (or loss subgroup) ceases to be a member.

(4) *Effect on corporations to which an apportionment is made—(i) Consolidated section 382 limitation.* The amount of the value element that is apportioned to a former member (or loss subgroup) is treated as the amount determined under section 382(b)(1) for purposes of determining the amount of that corporation's (or loss subgroup's) section 382 limitation for any taxable year ending after the former member (or loss subgroup) ceases to be a member(s). Appropriate adjustments must be made to the limitation based on the value element so apportioned for a short taxable year, carryforward of unused limitation, or any other adjustment required under section 382. The adjustment element apportioned to a former member (or loss subgroup) is treated as an adjustment under section 382(b)(2) or section 382(h), as appropriate, for the first taxable year after the member (or members) ceases to be a member (or members).

(ii) *Net unrealized built-in gain.* For purposes of determining the amount by which the former member's (or loss subgroup's) section 382 limitation for any taxable year beginning after the former member (or loss subgroup) ceases to be a member(s) is increased by its recognized built-in gain—

(A) The amount of net unrealized built-in gain apportioned to a former member (or loss subgroup) is treated as if it were an amount of net unrealized built-in gain determined under section 382(h)(1)(A)(i) (without regard to the threshold of section 382(h)(3)(B)) with respect to such member or loss subgroup, and that amount is not reduced under section 382(h)(1)(A)(ii) by the loss group's recognized built-in gain;

(B) The former member's (or loss subgroup's) 5 year recognition period begins on the loss group's change date;

(C) In applying section 382(h)(1)-(A)(ii), the former member (or loss subgroup) takes into account only its prior taxable years that begin after it ceases to be a member of the loss group; and

(D) The former member's (or loss subgroup's) recognized built-in gain on the disposition of an asset is determined under section 382(h)(2)(A), treating references to the change date in that section as references to the loss group's change date.

(5) *Deemed apportionment when loss group terminates.* If a loss group terminates, to the extent the consolidated section 382 limitation or net unrealized built-in gain is not apportioned under paragraph (c)(1) of this section, the consolidated section 382 limitation or net unrealized built-in gain is deemed to be apportioned to the loss subgroup that includes the common parent, or, if there is no loss subgroup that includes the common parent immediately after the loss group terminates, to the common parent. A loss group terminates on the first day of the first taxable year that is a separate return year with respect to each member of the former loss group.

(6) *Appropriate adjustments when former member leaves during the year.* Appropriate adjustments are made to the consolidated section 382 limitation for the consolidated return year during which the former member (or loss subgroup) ceases to be a member(s) to reflect the inclusion of the former member in the loss group for a portion of that year.

(7) *Examples.* The following examples illustrate the principles of this paragraph (c):

Example 1. Consequence of apportionment. (i) L owns all the L1 stock and L1 owns all the L2 stock. The L group has a \$200 consolidated net operating loss arising in Year 1 that is carried over to Year 2. At the close of December 31, Year 1, the group has an ownership change under §1.1502-92. The ownership change results in a consolidated section 382 limitation of \$10 based on the value of the stock of the group. On August 29, Year 2, L1 sells 30 percent of the stock of L2 to A. L2 is apportioned \$90 of the group's \$200 consolidated net operating loss under §1.1502-21(b). L, the common parent,

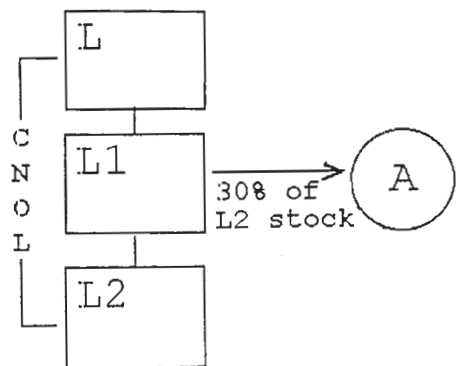

elects to apportion \$6 of the consolidated section 382 limitation to L2. The following is a graphic illustration of these facts:

(ii) For its separate return years ending after December 31, Year 2, L2's section 382 limitation with respect to the \$90 of the group's net operating loss apportioned to it is \$6, adjusted, as appropriate, for any short taxable year, unused section 382 limitation, or other adjustment. For its consolidated return year ending December 31, Year 2 the L group's consolidated section 382 limitation with respect to the remaining \$110 of pre-change consolidated attribute is \$4 (\$10 minus the \$6 value element apportioned to L2), adjusted, as appropriate, for any short taxable year, unused section 382 limitation, or other adjustment.

(iii) For the L group's consolidated return year ending December 31, Year 2, the value element of its consolidated section 382 limitation is increased by \$4 (rounded to the nearest dollar), to account for the period during which L2 was a member of the L group (\$6, the consolidated section 382 limitation apportioned to L2, times 241/365, the ratio of the number of days during Year 2 that L2 is a member of the group to the number of days in the group's consolidated return year). See paragraph (c)(6) of this section. Therefore, the value element of the consolidated section 382 limitation for Year 2 of the L group is \$8 (rounded to the nearest dollar).

(iv) The section 382 limitation for L2's short taxable year ending December 31, Year 2, is \$2 (rounded to the nearest dollar), which is the amount that bears the same relationship to \$6, the value element of the consolidated section 382 limitation apportioned to L2, as the number of days during that short taxable year, 124 days, bears to 365. See §1.382-5(c).

Example 2. Consequence of no apportionment. The facts are the same as in *Example 1*, except that L does not elect to apportion any portion of the consolidated section 382 limitation to L2. For its separate return years ending after August 29, Year 2, L2's section 382 limitation with respect to the \$90 of the group's pre-change consolidated attribute apportioned to L2 is zero under paragraph (b)(2)(ii) of this section. Thus, the \$90 consolidated net operating loss apportioned to L2 cannot offset L2's taxable income in any of its separate return years ending after August 29, Year 2. For its consolidated return years ending after August 29, Year 2, the L group's consolidated section 382 limitation with respect to the remaining \$110 of pre-change consolidated attribute is \$10, adjusted, as appropriate, for any short taxable year, unused section 382 limitation, or other adjustment.

Example 3. Apportionment of adjustment element. The facts are the same as in *Example 1*, except that L2 ceases to be a member of the L group on August 29, Year 3, and the L group has a \$4 carryforward of an unused consolidated section 382 limitation (under section 382(b)(2)) to the Year 3 consolidated return year. The carryover of unused section 382 limitation increases the consolidated section 382 limitation for the Year 3 consolidated return year from \$10 to \$14. L may elect to apportion all or any portion of the \$10 value element and all or any portion of the \$4 adjustment element to L2.

(d) *Rules pertaining to ceasing to be a member of a loss subgroup—(1) In gen-*

eral. A corporation ceases to be a member of a loss subgroup on the earlier of—

(i) The first day of the first taxable year for which it files a separate return; or

(ii) The first day that it ceases to bear a relationship described in section 1504(a)-(1) to the loss subgroup parent (treating for this purpose the loss subgroup parent as the common parent described in section 1504(a)(1)(A)).

(2) *Exceptions.* Paragraph (d)(1)(ii) of this section does not apply to a member of a loss subgroup while that member remains a member of the current group—

(i) If an election under §1.1502-91(d)(4)(relating to treating the subgroup parent requirement as satisfied) applies to the members of the loss subgroup;

(ii) Starting on the day after the change date (but not earlier than the date the loss subgroup becomes a member of the group), if there is an ownership change of the loss subgroup within six months before, on, or after becoming members of the group; or

(iii) Starting the day after the period of 5 consecutive years following the day that the loss subgroup become members of the group during which the loss subgroup has not had an ownership change.

(3) *Examples.* The principles of this paragraph (d) are illustrated by the following examples:

Example 1. Basic case. (i) P owns all the L stock, L owns all the L1 stock and L1 owns all the L2 stock. The P group has a consolidated net operating loss arising in Year 1 that is carried over to Year 2. On December 11, Year 2, P sells all the stock of L to corporation M. Each of L, L1, and L2 is apportioned a portion of the Year 1 consolidated net operating loss, and thereafter each joins with M in filing consolidated returns. Under §1.1502-92, the L loss subgroup has an ownership change on December 11, Year 2. The L loss subgroup has a subgroup section 382 limitation of \$100. The following is a graphic illustration of these facts:

(ii) On May 22, Year 3, L1 sells 40 percent of the L2 stock to A. L2 carries over a portion of the P group's net operating loss from Year 1 to its separate return year ending December 31, Year 3. Under paragraph (d)(1) of this section, L2 ceases to be a member of the L loss subgroup on May 22, Year 3, which is both (1) the first day of the first taxable year for which it files a separate return and (2) the day it ceases to bear a relationship described in section 1504(a)(1) to the loss subgroup parent, L. The net operating loss of L2 that is carried over from the P group is treated as a pre-change loss of L2 for its separate return years ending after May 22, Year 3. Under paragraphs (a)(2) and (b)(2) of this section, the separate section 382 limitation with respect to this loss is zero unless M elects to apportion all or a

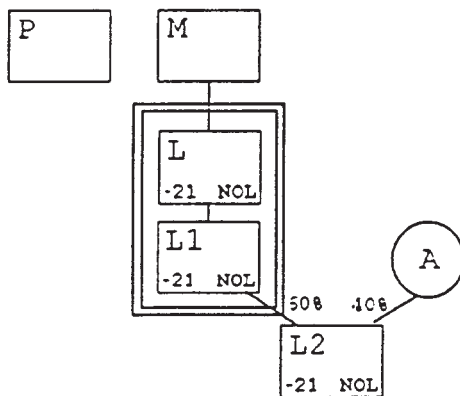
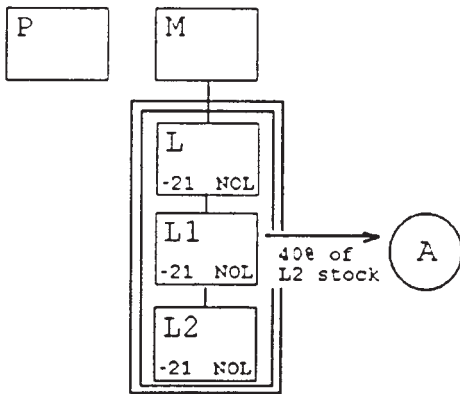
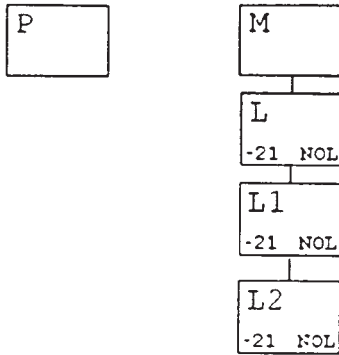
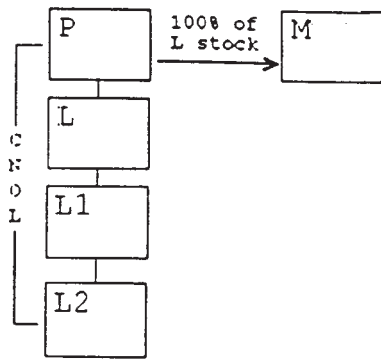

part of the subgroup section 382 limitation of the L loss subgroup to L2.

Example 2. Formation of a new loss subgroup. The facts are the same as in *Example 1*, except that A purchases 40 percent of the L1 stock from L rather than purchasing L2 stock from L1. L1 and L2 file a consolidated return for their first taxable year ending after May 22, Year 3, and each of L1 and L2 carries over a part of the net operating loss of the P group that arose in Year 1. Under paragraph (d)(1) of this section, L1 and L2 cease to be members of the L loss subgroup on May 22, Year 3. The net operating losses carried over from the P group are treated as pre-change subgroup attributes of the loss subgroup composed of L1 and L2. The subgroup section 382 limitation with respect to those losses is zero unless M elects to apportion all or part of the subgroup section 382 limitation of the L loss subgroup to the L1 loss subgroup. The following is a graphic illustration of these facts:

Example 3. Ownership change upon becoming members of the group. (i) A owns all the stock of P, and P owns all the stock of L1 and L2. The P group has a consolidated net operating loss arising in Year 1 that is carried over to Year 3 and Year 4. Corporation M acquires all the stock of P on November 11, Year 3, and P, L1, and L2 thereafter file consolidated returns with M. M's acquisition results in an ownership change of the P loss subgroup under §1.1502-92(b)(1)(ii).

(ii) P distributes the L2 stock to M on October 7, Year 4, and L2 ceases to bear the relationship described in section 1504(a)(1) to P, the P loss subgroup parent. However, under

paragraph (d)(2) of this section, L2 does not cease to be a member of the P loss subgroup because the P loss subgroup had an ownership change upon becoming members of the M group and L2 remains in the M group.

Example 4. Ceasing to bear a section 1504 (a)(1) to the loss subgroup parent. (i) A owns all the stock of P, and P owns all the stock of L1 and L2. The P group has a consolidated net operating loss arising in Year 1 that is carried over to Year 7. At the close of Year 2, X acquires all of the stock of P, causing an ownership change of the loss subgroup composed of P, L1 and L2 under §1.1502-92(b)(1)(ii). In Year 4, M, which is owned by the same person that owns X, acquires all of the stock of P, and the M acquisition does not cause a second ownership change of the P loss subgroup.

(ii) P distributes the L2 stock to M on February 3, Year 6 (less than 5 years after the P loss subgroup became members of the M group) and L2 ceases to bear the relationship described in section 1504(a)(1) to P, the loss subgroup parent. Thus, the section 382 limitation from the Year 2 ownership change that applies with respect to the pre-change attributes attributable to L2 is zero except to the extent M elects to apportion all or part of the P loss subgroup section 382 limitation to L2.

Example 5. Relationship through a successor. The facts are the same as in *Example 3*, except that M's acquisition of the P stock does not result in an ownership change of the P loss subgroup, and, instead of P's distributing the stock of L2, L2 merges into L1 on October 7, Year 4. L1 (as successor to L2 in the merger within the meaning of §1.1502-1(f)(4)) continues to bear a relationship described in

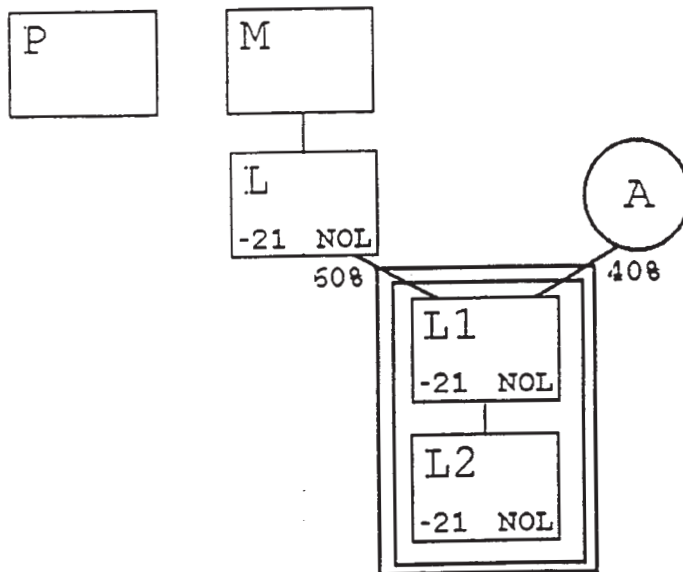
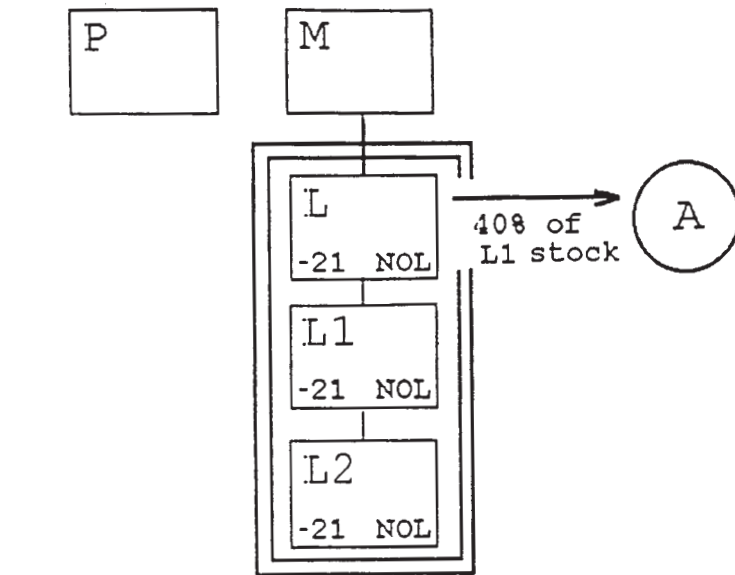

section 1504(a)(1) to P, the loss subgroup parent. Thus, L2 does not cease to be a member of the P loss subgroup as a result of the merger.

Example 6. Reattribution of net operating loss carryover under §1.1502-20(g). The facts are the same as in *Example 3*, except that, instead of distributing the L2 stock to M, P sells that stock to B, and, under §1.1502-20(g), M reattributes \$10 of L2's net operating loss carryover to itself. Under §1.1502-20(g), M succeeds to the reattributed loss as if the loss were succeeded to in a transaction described in section 381(a). M, as successor to L2, does not cease to be a member of the P loss subgroup.

(e) *Allocation of net unrealized built-in loss*—(1) *In general.* This paragraph (e) provides rules for the allocation of a loss

group's (or loss subgroup's) net unrealized built-in loss if a member ceases to be a member of a loss group (or loss subgroup). This paragraph (e) applies if—

(i) A loss group (or loss subgroup) has a net unrealized built-in loss on a change date; and

(ii) Immediately after the close of the consolidated return year in which the departing member ceases to be a member, the amount of the loss group's (or loss subgroup's) excess of net unrealized built-in loss over recognized built-in loss, determined under section 382(h)(1)(B)(ii) (relating to a limitation on recognized

built-in loss), is greater than zero. (The amount of such excess is referred to as the remaining NUBIL balance.) In applying section 382(h)(1)(B)(ii) for this purpose, net unrealized built-in loss allocated to departing members in prior consolidated return years is treated as recognized built-in loss in those years.

(2) *Amount of allocation*—(i) *In general.* The amount of net unrealized built-in loss allocated to a departing member is equal to the remaining NUBIL balance, multiplied by a fraction. The numerator of the fraction is the amount of the built-in loss, taken into account on the change date under §1.1502-91(g), in the assets held by the departing member immediately after the member ceases to be a member of the loss group (or loss subgroup). The denominator of the fraction is the sum of the numerator, plus the amount of the built-in loss, taken into account under §1.1502-91(g) on the change date, in the assets held by the loss group (or loss subgroup) immediately after the close of the taxable year in which the departing member ceases to be a member. (Fluctuations in value of the assets between the change date and the date that the member ceases to be a member of the group (or loss subgroup), or the close of the taxable year in which the member ceases to be a member of the loss group, are disregarded.) Because the amount of built-in loss on the change date with respect to a departing member's assets is taken into account (rather than that member's separately computed net unrealized built-in loss on the change date), a departing member can be apportioned all or part of the loss group's net unrealized built-in loss, even if the departing member had a separately computed net unrealized built-in gain on the change date. Amounts taken into account under section 382(h)(6)(C) (relating to certain deduction items) are treated as if they were assets in determining the numerator and denominator of the fraction.

(ii) *Transferred basis property and deferred gain or loss.* For purposes of paragraph (b)(2)(i) of this section, assets held by the departing member immediately after it ceases to be a member of the group (or by other members immediately after the close of the taxable year) include—

(A) Assets held at that time that are transferred basis property that was held

by any member of the group (or loss subgroup) on the change date; and

(B) Assets held at that time by any member of the consolidated group with respect to which gain or loss of the group member or loss subgroup member at issue has been deferred in an intercompany transaction and has not been taken into account.

(iii) *Assets for which gain or loss has been recognized.* For purposes of paragraph (b)(2)(i) of this section, assets held by the departing member immediately after it ceases to be a member of the group (or by other members immediately after the close of the taxable year) do not include assets with respect to which gain or loss has previously been recognized and taken into account during the recognition period (including gain or loss recognized in an intercompany transaction and taken into account immediately before the member leaves the group). Appropriate adjustments must be made if gain or loss on an asset has been only partially recognized and taken into account.

(iv) *Exchanged basis property.* The rules of § 1.1502-91(h) apply for purposes of this paragraph (e) (disregarding stock received from the departing member or another member that is a member immediately after the close of the taxable year).

(v) *Two or more members depart during the same year.* If two or more members cease to be members during the same consolidated return year, appropriate adjustments must be made to the denominator of the fraction for each departing member by treating the other departing members as if they had not ceased to be members during that year and as if the assets held by those other departing members immediately after they cease to be members of the group (or loss subgroup) are assets held by the group immediately after the close of the taxable year.

(vi) *Anti-abuse rule.* If assets are transferred between members or a member ceases to be a member with a principal purpose of causing or affecting the allocation of amounts under this paragraph (e), appropriate adjustments must be made to eliminate any benefit of such acquisition, disposition, or allocation.

(3) *Effect of allocation on the consolidated group.* The amount of the net unrealized built-in loss that is allocated to the former member is treated as recognized

built-in loss for a prior taxable year ending in the recognition period for purposes applying the limitation of section 382(h)(1)(B)(ii) to a loss group's (or loss subgroup's) recognition period taxable years beginning after the consolidated return year in which the former member ceases to be a member.

(4) *Effect on corporations to which the allocation is made.* For purposes of determining the amount of the former member's recognized built-in losses in any taxable year beginning after the former member ceases to be a member—

(i) The amount of the loss group's (or loss subgroup's) net unrealized built-in loss that is allocated to the former member is treated as if it were an amount of net unrealized built-in loss determined under section 382(h)(1)(B)(i) (without regard to the threshold of section 382(h)(3)-(B)) with respect to such member or loss subgroup, and that amount is not reduced under section 382(h)(1)(B)(ii) by the loss group's (or loss subgroup's) recognized built-in losses;

(ii) The former member's 5 year recognition period begins on the loss group's (or loss subgroup's) change date;

(iii) In applying section 382(h)(1)-(B)(ii), the former member takes into account only its prior taxable years that begin after it ceases to be a member of the loss group (or loss subgroup); and

(iv) The former member's recognized built-in loss on the disposition of an asset is determined under section 382(h)(2)(B), treating references to the change date in that section as references to the loss group's (or loss subgroup's) change date.

(5) *Subgroup principles.* If two or more former members are members of the same consolidated group (the second group) immediately after they cease to be members of the current group, the principles of paragraphs (e)(1), (2) and (4) of this section apply to those former members on an aggregate basis. Thus, for example, the amount of net unrealized built-in loss allocated to those members is based on the assets held by those members immediately after they cease to be members of the current group and the limitation of section 382(h)(1)(B)(ii) on recognized built-in losses is applied by taking into account the aggregate amount of net unrealized built-in loss allocated to the former members and the aggregate recognized

losses of those members in taxable years beginning after they cease to be members of the current group. If one or more of such members cease to be members of the second group, the principles of this paragraph (e) are applied with respect to those members to allocate to them all or part of any remaining unrecognized amount of net unrealized built-in loss allocated to the members that became members of the second group.

(6) *Apportionment of consolidated section 382 limitation (or subgroup section 382 limitation)—(i) In general.* For rules relating to the apportionment of a consolidated section 382 limitation (or subgroup section 382 limitation) to a former member, see paragraph (c) of this section.

(ii) *Special rule for former members that become members of the same consolidated group.* If recognized built-in losses of one or more former members would be subject to a consolidated section 382 limitation (or subgroup section 382 limitation) if recognized immediately before the member (or members) cease to be members of the group, an apportionment of that limitation may be made, under paragraph (c) of this section, to a loss subgroup that includes such member (or members), and the recognized built-in losses (if any) of that member (or members) will be subject to that apportioned limitation. If two or more of such former members are not included in a loss subgroup immediately after they cease to be members of the group (for example, because they do not have net operating loss carryovers or, in the aggregate, a net unrealized built-in loss), but are members of the same consolidated group, an apportionment of the consolidated section 382 limitation (or subgroup section 382 limitation) may be made to them as if they were a loss subgroup.

(7) *Examples.* The following examples illustrate the principles of this paragraph (e):

Example 1. Basic allocation case. (i) P owns all of the stock of L1 and L2. On September 4, Year 1, A purchases all of the P stock, causing an ownership change of the P group. On that date P has two assets (other than the L1 and L2 stock), asset 1 with an adjusted basis of \$40 and a fair market value of \$15 and asset 2 with an adjusted basis of \$50 and a fair market value of \$100. L1 has two assets, asset 3, with a fair market value of \$50 and an adjusted basis of \$100, and asset 4, with an adjusted basis of \$125 and a fair market value of \$75. L2 has two assets,

asset 5, with a fair market value of \$150 and an adjusted basis of \$100, and asset 6, with an adjusted basis of \$90 and a fair market value of \$40. Thus, the P loss group has a net unrealized built-in loss of \$75.

(ii) On March 19, Year 3, P sells all of the L2 stock to M. At that time, asset 5, which has appreciated in value, has a fair market value of \$250 and an adjusted basis of \$100. Asset 6, which has declined in value, has an adjusted basis of \$90 and a fair market value of \$10.

(iii) On April 8, Year 3, P sells asset 1, and has a recognized built-in loss of \$25 that is subject to the P group's section 382 limitation. On November 11, Year 4, L2 sells asset 6 for its then fair market value, \$10, recognizing a loss of \$80. On June 3, Year 5, L1 sells asset 4, recognizing a loss of \$50.

(iv) Immediately after the close of Year 3, the P loss group's remaining NUBIL balance is \$50 (\$75 net unrealized built-in loss reduced by the \$25 recognized built-in loss of P). The portion of the remaining NUBIL balance that is allocated to L2 is \$17 (rounded to the nearest dollar). Seventeen dollars is the product obtained by multiplying \$50 (the remaining NUBIL balance) by $\frac{50}{150}$. The numerator of the fraction ($\$50$) is the amount of built-in loss in asset 6, taken into account on the change date under §1.1502-91(g). The denominator ($\$150$) is the sum of the numerator ($\$50$) and the amount of built-in loss in assets 3 and 4, taken into account on the change date under §1.1502-91(g) ($\$100$). The built-in loss in asset 1 is not included in the denominator of the fraction because it is not held by the P group immediately after the close of Year 3.

(v) Seventeen dollars of L2's \$80 loss on the sale of asset 6 is a recognized built-in loss and subject to a section 382 limitation of zero, unless P apportions some or all of the P group's consolidated section 382 limitation to L2 (adjusted for a short taxable year, carryover of unused limitation, or any other adjustment required under section 382).

(vi) Thirty-three dollars of L1's \$50 loss on the sale of asset 4 is subject to the P group's consolidated section 382 limitation, reduced by the amount of such limitation apportioned to L2, and adjusted for any short taxable year, a carryforward of unused limitation, or other adjustment. (In applying section 382(h)(1)(B)(ii) with respect to Year 5, the P group's net unrealized built-in loss is reduced by P's \$25 recognized built-in loss in Year 3 and the \$17 of net unrealized built-in loss allocated to L2, thus limiting the P group's recognized built-in loss in Year 5 to \$33.)

Example 2. Two members depart in the same year. The facts are the same as in *Example 1*, except that P sells all of the stock of L1 to C on November 1, Year 3. The amount of net unrealized built-in loss apportioned to L2 (rounded to the nearest dollar) is \$17 ($\$50 \text{ remaining NUBIL balance} \times \frac{\$50}{\$150}$). The amount of net unrealized built-in loss apportioned to L1 (rounded to the nearest dollar) is \$33 ($\$50 \text{ remaining NUBIL balance} \times \frac{\$100}{\$150}$).

(8) Reporting requirement. If a net unrealized built-in loss is allocated under this paragraph (e), the common parent must file a statement with its income tax return for the taxable year in which the former member(s) (or a new loss sub-

group that includes that member) ceases to be a member. The statement must provide the name and employer identification number (E.I.N.) of the departing member, the amount of remaining NUBIL balance for the taxable year in which the member departs, and the amount of the net unrealized built-in loss allocated to the departing member. The common parent must also deliver a copy of the statement to the former member on or before the day the group files its income tax return for the consolidated return year that the former member ceases to be a member. A copy of the statement must be attached to the first income tax return of the former member (or the first return in which the former member joins) that is filed after the close of the consolidated return year of the group of which the former member (or a new loss subgroup that includes that member) ceases to be a member. This paragraph (e)(8) does not apply if the required information (other than the amount of remaining NUBIL balance) is included in a statement of election under paragraph (f) of this section (relating to apportioning a section 382 limitation).

(f) Filing the election to apportion the section 382 limitation and net unrealized built-in gain—(1) Form of the election to apportion. An election under paragraph (c) of this section must be made by the common parent. The election must be made in the form of the following statement: “THIS IS AN ELECTION UNDER §1.1502-95 OF THE INCOME TAX REGULATIONS TO APPORTION ALL OR PART OF THE [insert THE CONSOLIDATED SECTION 382 LIMITATION, THE SUBGROUP SECTION 382 LIMITATION, THE LOSS GROUP'S NET UNREALIZED BUILT-IN GAIN, THE LOSS SUBGROUP'S NET UNREALIZED BUILT-IN GAIN, as appropriate] TO [insert name and E.I.N. of the corporation (or the corporations that compose a new loss subgroup) to which allocation is made]”. The declaration must also include the following information, as appropriate—

(i) The date of the ownership change that resulted in the consolidated section 382 limitation (or subgroup section 382 limitation) or the loss group's (or loss subgroup's) net unrealized built-in gain;

(ii) The amount of the departing member's (or loss subgroup's) pre-change net

operating loss carryovers and the taxable years in which they arose that will be subject to the limitation that is being apportioned to that member (or loss subgroup);

(iii) The amount of any net unrealized built-in loss allocated to the departing member (or loss subgroup) under paragraph (e) of this section, which, if recognized, can be a pre-change attribute subject to the limitation that is being apportioned;

(iv) If a consolidated section 382 limitation (or subgroup section 382 limitation) is being apportioned, the amount of the consolidated section 382 limitation (or subgroup section 382 limitation) for the taxable year during which the former member (or new loss subgroup) ceases to be a member of the consolidated group (determined without regard to any apportionment under this section);

(v) If any net unrealized built-in gain is being apportioned, the amount of the loss group's (or loss subgroup's) net unrealized built-in gain (as determined under paragraph (c) (2)(ii) of this section) that may be apportioned to members that ceased to be members during the consolidated return year;

(vi) The amount of the value element and adjustment element of the consolidated section 382 limitation (or subgroup section 382 limitation) that is apportioned to the former member (or new loss subgroup) pursuant to paragraph (c) of this section;

(vii) The amount of the loss group's (or loss subgroup's) net unrealized built-in gain that is apportioned to the former member (or new loss subgroup) pursuant to paragraph (c) of this section;

(viii) If the former member is allocated any net unrealized built-in loss under paragraph (e) of this section, the amount of any adjustment element apportioned to the former member that is attributable to recognized built-in gains (determined in a manner that will enable both the group and the former member to apply the principles of §1.1502-93(c));

(ix) The name and E.I.N. of the common parent making the apportionment.

(2) Signing of the election. The election statement must be signed by both the common parent and the former member (or, in the case of a loss subgroup, the common parent and the loss subgroup parent) by persons authorized to sign their

respective income tax returns. If the allocation is made to a loss subgroup for which an election under §1.1502-91(d)(4) is made, and not separately to its members, the election statement under this paragraph (e) must be signed by the common parent and any member of the new loss subgroup by persons authorized to sign their respective income tax returns.

(3) *Filing of the election.* The election statement must be filed by the common parent of the group that is apportioning the consolidated section 382 limitation (or the subgroup section 382 limitation) or the loss group's net unrealized built-in gain (or loss subgroup's net unrealized built-in gain) with its income tax return for the taxable year in which the former member (or new loss subgroup) ceases to be a member. The common parent must also deliver a copy of the statement to the former member (or the members of the new loss subgroup) on or before the day the group files its income tax return for the consolidated return year that the former member (or new loss subgroup) ceases to be a member. A copy of the statement must be attached to the first return of the former member (or the first return in which the members of a new loss subgroup join) that is filed after the close of the consolidated return year of the group of which the former member (or the members of a new loss subgroup) ceases to be a member.

(4) *Revocation of election.* An election statement made under paragraph (c) of this section is revocable only with the consent of the Commissioner.

§1.1502-96 Miscellaneous rules.

(a) *End of separate tracking of losses—(1) Application.* This paragraph (a) applies to a member (or a loss subgroup) with a net operating loss carryover that arose (or is treated under §1.1502-21(c) as arising) in a SRLY, or a member (or loss subgroup) with a net unrealized built-in loss determined at the time that the member (or loss subgroup) becomes a member of the consolidated group if there is—

(i) An ownership change of the member (or loss subgroup) within six months before, on, or after becoming a member of the group; or

(ii) A period of 5 consecutive years following the day that the member (or loss

subgroup) becomes a member of a group during which the member (or loss subgroup) has not had an ownership change.

(2) *Effect of end of separate tracking—(i) Net operating loss carryovers.* If this paragraph (a) applies with respect to a member (or loss subgroup) with a net operating loss carryover, then, starting on the day after the earlier of the change date (but not earlier than the day the member (or loss subgroup) becomes a member of the consolidated group) or the last day of the 5 consecutive year period described in paragraph (a)(1)(ii) of this section, such loss carryover is treated as described in §1.1502-91(c)(1)(i). The preceding sentence also applies for purposes of determining whether there is an ownership change with respect to such loss carryover following such change date or 5 consecutive year period. Thus, for example, starting the day after the change date (but not earlier than the day the member (or loss subgroup) becomes a member of the consolidated group) or the end of the 5 consecutive year period—

(A) The consolidated group which includes the new loss member or loss subgroup is no longer required to separately track owner shifts of the stock of the new loss member or subgroup parent to determine if an ownership change occurs with respect to the loss carryover of the new loss member or members included in the loss subgroup;

(B) The group is a loss group because the member's loss carryover is treated as a loss described in §1.1502-91(c)(1)(i);

(C) There is an ownership change with respect to such loss carryover only if the group has an ownership change; and

(D) If the group has an ownership change, such loss carryover is a pre-change consolidated attribute subject to the loss group's consolidated section 382 limitation.

(ii) *Net unrealized built-in losses.* If this paragraph (a) applies with respect to a new loss member described in §1.1502-94 (a)(1)(ii) (or a loss subgroup described in §1.1502-91(d)(2)) then, starting on the day after the earlier of the change date (but not earlier than the day the member (or loss subgroup) becomes a member of the group) or the last day of the 5 consecutive year period described in paragraph (a)(1)(ii) of this section, the member (or members of the loss subgroup) are

treated, for purposes of applying §1.1502-91(g)(2)(ii), as if they have been affiliated with the common parent for 5 consecutive years. Starting on that day, the member's (or the members of the loss subgroup's) separately computed net unrealized built-in loss is included in the determination whether the group has a net unrealized built-in loss, and there is an ownership change with respect to the member's separately computed net unrealized built-in loss only if the group (including the member) has a net unrealized built-in loss and has an ownership change. Thus, for example, starting the day after the change date (but not earlier than the day the member (or loss subgroup) becomes a member of the consolidated group), or the end of the 5 consecutive period—

(A) The consolidated group which includes the new loss member or loss subgroup is no longer required to separately track owner shifts of the stock of the new loss member or subgroup parent to determine if an ownership change occurs with respect to the net unrealized built-in loss of the new loss member or members of the loss subgroup;

(B) The group includes the member's (or the loss subgroup members') separately computed net unrealized built-in loss in determining whether it is a loss group under §1.1502-91(c)(1)(iii);

(C) There is an ownership change with respect to such net unrealized built-in loss only if the group is a loss group and has an ownership change; and

(D) If the group has an ownership change, the member's separately computed net unrealized built-in loss and its assets are taken into account in determining the group's pre-change consolidated attributes described in §1.1502-91(e)(1) (relating to recognized built-in losses) that are subject to the group's consolidated section 382 limitation.

(iii) *Common parent not common parent for five years.* If the common parent has become the common parent of an existing group within the previous 5-year period in a transaction described in §1.1502-75(d)(2)(ii) or (3), appropriate adjustments must be made in applying paragraphs (a)(2)(ii) and (3) of this section. In such a case, as the context requires, references to the common parent are to the former common parent.

(3) *Continuing effect of end of separate tracking*—(i) *In general.* As the context may require, a current group determines which of its members are included in a loss subgroup on any testing date by taking into account the application of this section in the former group. See the example in §1.1502–91(f)(2). For this purpose, corporations that are treated under paragraph (a)(2)(ii) of this section as having been affiliated with the common parent of the former group for 5 consecutive years are also treated as having been affiliated with any other members that have been (or are treated as having been) affiliated with the common parent. The corporations are treated as having been affiliated with such other members for the same period of time that those members have been (or are treated as having been) affiliated with the common parent. If two or more corporations become members of the group at the same time, but paragraph (a)(1) of this section does not apply to every such corporation, then immediately after the corporations become members of the group, the corporations to which paragraph (a)(1) of this section applied are treated as not having been previously affiliated, for purposes of applying this paragraph (a)(3), with the corporations to which paragraph (a)(2)(ii) of this section did not apply.

(ii) *Example.* The following example illustrates the principles of this paragraph (a)(3):

Example. (i) L has owned all the stock of L1 for three years. At the close of December 31, Year 1, the M group purchases all the L stock, and L and L1 become members of the M group. Other than the stock of L1, L has one asset (the L loss asset) with a net unrealized built-in loss of \$200 on this date. L1 has one asset with a net unrealized built-in gain of \$50 (the L1 gain asset). L and L1 do not compose a loss subgroup because they do not meet the five year affiliation requirement of §1.1502–91(d)(2)(i). L is a new loss member, and M's purchase of L causes an ownership change of L. At the close of December 31, Year 4, at a time when L1 has been affiliated with the M group for three years and has been affiliated with L for six years, the S group purchases all the M stock. On this date, the L loss asset has a net unrealized built-in loss of \$300, the L1 gain asset has a net unrealized built-in gain of \$80, and M, the common parent of the M group, has one asset with a net unrealized built-in gain of \$200.

(ii) Paragraph (a)(1) of this section applies to L because L is a new loss member described in §1.1502–94(a)(1)(ii) that has an ownership change upon becoming a member of the M group on December 31, Year 1. Accordingly, L is treated as having been affiliated with M for 5 consecutive years,

and the L loss asset with a net unrealized built-in loss of \$300 is included in the determination whether the M group has a net unrealized built-in loss.

(iii) The S group determines which of its members are included in a loss subgroup by taking into account application of paragraph (a) of this section in the M group. For this purpose, application of paragraph (a) of this section causes L to be treated as having been affiliated with M (or as having been a member of the M group) for 5 consecutive years as of January 1, Year 2. Therefore, the S group includes L in the determination whether the M subgroup acquired by S on December 31, Year 4, has a net unrealized built-in loss.

(iv) Because paragraph (a)(1) of this section applied to L when L became a member of the M group, but did not apply to L1, L is treated as not having been affiliated with L1 before L and L1 joined the M group. Also, L1 is not included in the determination whether the M subgroup has a net unrealized built-in loss because L1 has not been continuously affiliated with members of the M group for the five consecutive year period ending immediately before they become members of the S group. See §1.1502–91(g)(2).

(4) *Special rule for testing period.* For purposes of determining the beginning of the testing period for a loss group, the member's (or loss subgroup's) net operating loss carryovers (or net unrealized built-in loss) described in paragraph (a)(2) of this section are considered to arise—

(i) In a case described in paragraph (a)(1)(i) of this section, in a taxable year that begins not earlier than the later of the day following the change date or the day that the member becomes a member of the group; and

(ii) In a case described in paragraph (a)(1)(ii) of this section, in a taxable year that begins 3 years before the end of the 5 consecutive year period.

(5) *Limits on effects of end of separate tracking.* The rule contained in this paragraph (a) applies solely for purposes of §§1.1502–91 through 1.1502–95 and this section (other than paragraph (b)(2)(ii)(B) of this section (relating to the definition of pre-change attributes of a subsidiary)) and §1.1502–98, and not for purposes of other provisions of the consolidated return regulations. However, the rule contained in this paragraph (a) does apply in §§1.1502–15(g), 1.1502–21(g) and 1.1502–22(g) for purposes of determining the composition of loss subgroups defined in §1.1502–91(d). See also paragraph (c) of this section for the continuing effect of an ownership change with respect to pre-change attributes.

(b) *Ownership change of subsidiary*—(1) *Ownership change of a subsidiary because of options or plan or arrangement.* Notwithstanding §1.1502–92, a subsidiary may have an ownership change for purposes of section 382 with respect to its attributes which a group or loss subgroup includes in making a determination under §1.1502–91(c)(1) (relating to the definition of loss group) or §1.1502–91(d) (relating to the definition of loss subgroup). The subsidiary has such an ownership change if it has an ownership change under the principles of §1.1502–95(b) and section 382 and the regulations thereunder (determined on a separate entity basis by treating the subsidiary as not being a member of a consolidated group) in the event of—

(i) The deemed exercise under §1.382–4(d) of an option or options (other than an option with respect to stock of the common parent) held by a person (or persons acting pursuant to a plan or arrangement) to acquire more than 20 percent of the stock of the subsidiary; or

(ii) An increase by 1 or more 5-percent shareholders, acting pursuant to a plan or arrangement to avoid an ownership change of a subsidiary, in their percentage ownership interest in the subsidiary by more than 50 percentage points during the testing period of the subsidiary through the acquisition (or deemed acquisition pursuant to §1.382–4(d)) of ownership interests in the subsidiary and in higher-tier members with respect to the subsidiary.

(2) *Effect of the ownership change*—(i) *In general.* If a subsidiary has an ownership change under paragraph (b)(1) of this section, the amount of consolidated taxable income for any post-change year that may be offset by the pre-change losses of the subsidiary shall not exceed the section 382 limitation for the subsidiary. For purposes of this limitation, the value of the subsidiary is determined solely by reference to the value of the subsidiary's stock.

(ii) *Pre-change losses.* The pre-change losses of a subsidiary are—

(A) Its allocable part of any consolidated net operating loss which is attributable to it under §1.1502–21(b) (determined on the last day of the consolidated return year that includes the change date) that is not carried back and absorbed in a taxable year prior to the year including the change date;

(B) Its net operating loss carryovers that arose (or are treated under §1.1502–21(c) as having arisen) in a SRLY; and

(C) Its recognized built-in loss with respect to its separately computed net unrealized built-in loss, if any, determined on the change date.

(3) *Coordination with §§1.1502–91, 1.1502–92, and 1.1502–94.* If an increase in percentage ownership interest causes an ownership change with respect to an attribute under this paragraph (b) and under §1.1502–92 on the same day, the ownership change is considered to occur only under §1.1502–92 and not under this paragraph (b). See §1.1502–94 for anti-duplication rules relating to value.

(4) *Example.* The following example illustrates paragraph (b)(1)(ii) of this section:

Example. Plan to avoid an ownership change of a subsidiary. (i) L owns all the stock of L1, L1 owns all the stock of L2, L2 owns all the stock of L3, and L3 owns all the stock of L4. The L group has a consolidated net operating loss arising in Year 1 that is carried over to Year 2. L has assets other than its L1 stock with a value of \$900. L1, L2, and L3 own no assets other than their L2, L3, and L4 stock. L4 has assets with a value of \$100. During Year 2, A, B, C, and D, acting pursuant to a plan to avoid an ownership change of L4, acquire the following ownership interests in the members of the L loss group: (A) on September 11, Year 2, A acquires 20 percent of the L1 stock from L and B acquires 20 percent of the L2 stock from L1; and (B) on September 20, Year 2, C acquires 20 percent of the stock of L3 from L2 and D acquires 20 percent of the stock of L4 from L3.

(ii) The acquisitions by A, B, C, and D pursuant to the plan have increased their respective percentage ownership interests in L4 by approximately 10, 13, 16, and 20 percentage points, for a total of approximately 59 percentage points during the testing period. This more than 50 percentage point increase in the percentage ownership interest in L4 causes an ownership change of L4 under paragraph (b)(2) of this section.

(c) *Continuing effect of an ownership change.* A loss corporation (or loss subgroup) that is subject to a limitation under section 382 with respect to its pre-change losses continues to be subject to the limitation regardless of whether it becomes a member or ceases to be a member of a consolidated group. See §1.382–5(d) (relating to successive ownership changes and absorption of a section 382 limitation).

(d) *Losses reattributed under §1.1502–20(g)—(1) In general.* This paragraph (d) contains rules relating to net operating carryovers that are reattributed to the

common parent under §1.1502–20(g). References in this paragraph (d) to a subsidiary are references to the subsidiary (or lower tier subsidiary) whose net operating loss carryover is reattributed to the common parent.

(2) *Deemed section 381(a) transaction.* Under §1.1502–20 (g)(1), the common parent succeeds to the reattributed losses as if the losses were succeeded to in a transaction described in section 381(a). In general, §§1.1502–91 through 1.1502–95, this section, and §1.1502–98 are applied to the reattributed net operating loss carryovers in accordance with that characterization. See generally, §1.382–2(a)(1)(ii) (relating to distributor or transferor loss corporations in transactions under section 381), §1.1502–(1)(f)(4) (relating to the definition of predecessor and successor) and §1.1502–91(j) (relating to predecessor and successor corporations). For example, if the reattributed net operating loss carryover is a pre-change attribute subject to a section 382 limitation, it remains subject to that limitation following the reattribution. In certain cases, the limitation applicable to the reattributed loss is zero unless the common parent apportions all or part of the limitation to itself. (See paragraph (d)(4) of this section.)

(3) *Rules relating to owner shifts—(i) In general.* Any owner shift of the subsidiary (including any deemed owner shift resulting from section 382(g)(4)(D) or 382(l)(3)) in connection with the disposition of the stock of the subsidiary is not taken into account in determining whether there is an ownership change with respect to the reattributed net operating loss carryover. However, any owner shift with respect to the successor corporation that is treated as continuing in existence under §1.382–2(a)(1)(ii) must be taken into account for such purpose if such owner shift is effected by the reattribution and an owner shift of the stock of the subsidiary not held directly or indirectly by the common parent would have been taken into account if such shift had occurred immediately before the reattribution. See paragraph (d)(3)(ii) *Example 2* of this section.

(ii) *Examples.* The following examples illustrate the principles of this paragraph (d)(3):

Example 1. No owner shift for reattributed loss.
(i) P, the common parent of a consolidated group,

owns 60% of the stock of L, and B owns the remaining 40%. L has a net operating loss carryover of \$100 from year 1 that it carries over to Years 2, 3, and 4. At the beginning of Year 2, P purchases 40% of the L stock from B, which does not cause an ownership change of L. On December 31, Year 3, P sells all of the L stock to M. Pursuant to §1.1502–20(g), P reattributes \$10 of L's \$100 net operating loss carryover to itself, and L carries \$90 of its net operating loss carryover to its Year 4.

(ii) The sale of the L stock to M does not cause an owner shift that is taken into account in determining if there is an ownership change with respect to the \$10 reattributed loss. Following the reattribution, §1.1502–94(b) continues to apply to determine if there is an ownership change with respect to the \$10 reattributed loss, until, under paragraph (a) of this section, the loss is treated as described in §1.1502–91(c)(1)(i). In applying §1.1502–94(b), the 40 percentage point increase by the P shareholders prior to the reattribution is taken into account. The sale of the L stock to M does cause an ownership change of L with respect to the \$90 of its net operating loss that it carries over to Year 4.

Example 2. Owner shift for reattributed loss. The facts are the same as in *Example 1*, except that P only purchases 20% of the L stock from B and sells 80% of the L stock to M. L is a new loss member, and, under §1.1502–94(b)(1), an owner shift of the stock of L not held directly or indirectly by the common parent (the 20% of L stock still held by B) would have been taken into account if such shift had occurred immediately before the reattribution. Following the reattribution, §1.1502–94(b) continues to apply to determine if there is an ownership change with respect to the \$10 reattributed loss, until, under paragraph (a) of this section, the loss is treated as described in §1.1502–91(c)(1)(i). With respect to the \$10 reattributed loss, the P shareholders have increased their percentage ownership interest by 40 percentage points. The P shareholders have increased their ownership interests by 20 percentage points as a result of P's purchase of stock from B, and, under §1.382–2(a)(1)(ii), are treated as increasing their interests by an additional 20 percentage points as a result of the reattribution. (The acquisition of the L stock by M does not, however, effect an owner shift for the \$10 of reattributed loss.) The sale of the L stock to M causes an ownership change of L with respect to the \$90 of net operating loss that L carries over to Year 4.

(4) *Rules relating to the section 382 limitation—(i) Reattributed loss is a pre-change separate attribute of a new loss member.* If the reattributed net operating loss carryover is a pre-change separate attribute of a new loss member that is subject to a separate section 382 limitation prior to the disposition of subsidiary stock, the common parent's limitation with respect to that loss is zero, except to the extent that the common parent apportions to itself, under paragraph (d)(5) of this section, all or part of such limitation. A separate section 382 limitation is the

limitation described in §1.1502–94(b) that applies to a pre-change separate attribute.

(ii) *Reattributed loss is a pre-change subgroup attribute.* If the reattributed net operating loss carryover is a pre-change subgroup attribute subject to a subgroup section 382 limitation prior to the disposition of subsidiary stock, and, immediately after the reattribution, the common parent is not a member of the loss subgroup, the section 382 limitation with respect to that net operating loss carryover is zero, except to the extent that the common parent apportions to itself, under paragraph (d)(5) of this section, all or part of the subgroup section 382 limitation. See, however, §1.1502–95(d)(3) *Example 6*, for an illustration of a case where the common parent, as successor to the subsidiary, is a member of the loss subgroup immediately after the reattribution.

(iii) *Potential application of section 382(l)(1).* In general, the value of the stock of the common parent is used to determine the section 382 limitation for an ownership change with respect to the reattributed net operating loss carryover that occurs at the time of, or after, the reattribution. For example, if the net operating loss carryover is a pre-change consolidated attribute, the value of the stock of the common parent is used to determine the section 382 limitation, and no adjustment to that value is required because of the deemed section 381(a) transaction. However, if the net operating loss carryover is a pre-change separate attribute of a new loss member (or is a pre-change attribute of a loss subgroup member and the common parent was not the loss subgroup parent immediately before the reattribution), the deemed section 381(a) transaction is considered to constitute a capital contribution with respect to the new loss member (or loss subgroup member) for purposes of section 382(l)(1). Accordingly, if that section applies because the deemed capital contribution is (or is considered under section 382(l)(1)(B) to be) part of a plan described in section 382(l)(1)(A), the value of the stock of the common parent after the deemed section 381(a) transaction must be adjusted to reflect the capital contribution. Ordinarily, this will require the value of the stock of the common parent to be reduced to an amount that represents the value of the

stock of the subsidiary (or loss subgroup of which the subsidiary was a member) when the reattribution occurred.

(iv) *Duplication or omission of value.* In determining any section 382 limitation with respect to the reattributed net operating loss carryover and with respect to other pre-change losses, appropriate adjustments must be made so that value is not improperly omitted or duplicated as a result of the reattribution. For example, if the subsidiary has an ownership change upon its departure, and the common parent (as successor) has an ownership change with respect to the reattributed pre-change separate attribute upon its reattribution under paragraph (d)(3)(i) of this section, proper adjustments must be made so that the value of the subsidiary is not taken into account more than once in determining the section 382 limitation for the reattributed loss and the loss that is not reattributed.

(v) *Special rule for continuity of business requirement.* If the reattributed net operating loss carryover is a pre-change attribute of new loss member and the reattribution occurs within the two year period beginning on the change date, then, starting immediately after the reattribution, the continuity of business requirement of section 382(c)(1) is applied with respect to the business enterprise of the common parent. Similar principles apply if the reattributed net operating loss carryover is a pre-change subgroup attribute and, on the day after the reattribution, the common parent is not a member of the loss subgroup.

(5) *Election to reattribute section 382 limitation—(i) Effect of election.* The common parent may elect to apportion to itself all or part of any separate section 382 limitation or subgroup section 382 limitation to which the net operating loss carryover is subject immediately before the reattribution. However, no net unrealized built-in gain of the member (or loss subgroup) whose net operating loss carryover is reattributed can be apportioned to the common parent. The principles of §1.1502–95(c) apply to the apportionment, treating, as the context requires, references to the former member as references to the common parent, and references to the consolidated section 382 limitation as references to the separate section 382 limitation (or subgroup sec-

tion 382 limitation) that is being apportioned. Thus, for example, the common parent can reattribute to itself all or part of the value element or adjustment element of the limitation, and any part of such element that is apportioned requires a corresponding reduction in such element of the separate section 382 limitation of the subsidiary whose net operating loss carryover is reattributed (or in the subgroup section 382 limitation if the reattributed loss is a pre-change subgroup attribute). Appropriate adjustments must be made to the separate section 382 limitation (or subgroup section 382 limitation) for the consolidated return year in which the reattribution is made to reflect that the reattributed net operating loss carryover is an attribute acquired by the common parent during the year in a transaction to which section 381(a) applies. The election is made by the common parent as part of the election to reattribute the net operating loss carryover. See §1.1502–20(g)-(4) for the time and manner of making the election.

(ii) *Examples.* The following examples illustrate the principles of this paragraph (d)(5):

Example 1. Consequence of apportionment. (i) P, the common parent of a consolidated group, purchases all of the stock of L on December 31, Year 1. L carries over a net operating loss arising in Year 1 to each of the next 5 taxable years. The purchase of the L stock causes an ownership change of L, and results in a separate section 382 limitation of \$10 for L's net operating loss carryover based on the value of the L stock. On July 2, Year 3, P sells 30 percent of the L stock to A. Under §1.1502–20(g), P elects to apportion to itself \$110 of L's \$200 net operating loss carryover. P also elects to apportion to itself \$6 of the \$10 value element of the separate section 382 limitation.

(ii) For the consolidated return years ending after December 31, Year 3, P's separate section 382 limitation with respect to the reattributed net operating loss carryover is \$6, adjusted as appropriate for any short taxable year, unused section 382 limitation, or other adjustment. For the P group's consolidated return year ending December 31, Year 3, the separate section 382 limitation for L's net operating loss carryover is \$8, the sum of \$5 and \$3. Five dollars of the limitation is the amount that bears the same relationship to \$10 as the number of days in the period ending with the deemed section 381(a) transaction, 183 days, bears to 365. Three dollars of the limitation is the amount that bears the same relationship to \$6 as the number of days in the period between July 3 and December 31, 182, bears to 365.

(iii) For L's taxable years ending after December 31, Year 3, L's separate section 382 limitation for its \$90 of net operating loss carryover that was not reattributed to P is \$4, adjusted as appropriate for any

short taxable year, unused section 382 limitation, or other adjustment. For L's short taxable year ending December 31, Year 3, the section 382 limitation for its \$90 of net operating loss carryover is \$2, the amount that bears the same relationship to \$4 (the portion of the value element that was not apportioned to P), as the number of days during the short taxable year, 182 days, bears to 365. See §1.382-5(c).

Example 2. No apportionment required for consolidated pre-change attribute. (i) P, the common parent of a consolidated group, forms L. For Year 1, L has an operating loss of \$70 that is not absorbed and is included in the group's consolidated net operating loss that is carried over to subsequent years. On January 1 of Year 3, A buys all of the P stock and the P group has an ownership change. The consolidated section 382 limitation based on the value of the P stock is \$10.

(ii) On April 13 of Year 4, P sells all of the stock of L to B and, under §1.1502-20(g), elects to reattribute to itself \$45 of L's net operating loss carryover. Following the reattribution, the \$45 portion of the Year 1 net operating loss carryover retains its character as a pre-change consolidated attribute, and remains subject to so much of the \$10 consolidated section 382 limitation as P does not elect to apportion to L under §1.1502-95(c).

(e) *Time and manner of making election under §1.1502-91(d)(4)*—(1) *In general.* This paragraph (e) prescribes the time and manner of making the election under §1.1502-91(d)(4), relating to treating two or more corporations as treating the section 1504(a)(1) requirement of §1.1502-91(d)(1)(ii) and (d)(2)(ii) as satisfied.

(2) *Election statement.* An election under §1.1502-91(d)(4) must be made by the common parent. The election must be made in the form of the following statement: "THIS IS AN ELECTION UNDER §1.1502-91(d)(4) TO TREAT THE FOLLOWING CORPORATIONS AS MEETING THE REQUIREMENTS OF §1.1502-91(d)(1)(ii) AND (d)(2)(ii) IMMEDIATELY AFTER THEY BECAME MEMBERS OF THE GROUP." [List separately the name of each corporation, its E.I.N., and the date that it became a member of the group]. If separate elections are being made for corporations that became members at different times or that were acquired from different affiliated groups, provide a separate statement and list for each election.

(3) The election statement must be filed by the common parent with its income tax return for the consolidated return year in which the members with respect to which the election is made become members of the group. Such election must be filed on

or before the due date for such income tax return, including extensions.

(4) An election made under this paragraph (e) is irrevocable.

§1.1502-97 *Special rules under section 382 for members under the jurisdiction of a court in a title II or similar case.*

[Reserved]

§1.1502-98 *Coordination with section 383.*

The rules contained in §§1.1502-91 through 1.1502-96 also apply for purposes of section 383, with appropriate adjustments to reflect that section 383 applies to credits and net capital losses. Similarly, in the case of net capital losses, general business credits, and excess foreign taxes that are pre-change attributes, §1.383-1 applies the principles of §§1.1502-91 through 1.1502-96. For example, if a loss group has an ownership change under §1.1502-92 and has a carryover of unused general business credits from a pre-change consolidated return year to a post-change consolidated return year, the amount of the group's regular tax liability for the post-change year that can be offset by the carryover cannot exceed the consolidated section 383 credit limitation for that post-change year, determined by applying the principles of §§1.383-1(c)(6) and 1.1502-93 (relating to the computation of the consolidated section 382 limitation).

§1.1502-99 *Effective dates.*

(a) *In general.* Except as provided in paragraphs (b) and (c) of this section, §§1.1502-91 through 1.1502-96 and §1.1502-98 apply to any testing date on or after June 25, 1999. Sections 1.1502-94 through 1.1502-96 also apply to a corporation that becomes a member of a group or ceases to be a member of a group (or loss subgroup) on any date on or after June 25, 1999.

(b) *Special rules*—(1) *Election to treat subgroup parent requirement as satisfied.* Section 1.1502-91(d)(4), §1.1502-91(d)(7), *Example 4*, §1.1502-92(b)(1)(iii), §1.1502-92(b)(2), *Example 5*, the last two sentences of §1.1502-95(b)(3), §1.1502-95(d)(2)(i), and §1.1502-96(e) (all of which relate to the election under §1.1502-91(d)(4) to treat the loss sub-

group parent requirement as satisfied) apply to corporations that become members of a consolidated group in taxable years for which the due date of the income tax return (without extensions) is after June 25, 1999.

(2) *Principal purpose of avoiding a limitation.* The third sentence of §1.1502-91(d)(5) (relating to members excluded from a loss subgroup) applies to corporations that become members of a consolidated group on or after June 25, 1999.

(3) *Ceasing to be a member of a loss subgroup*—(i) *Ownership change of a loss subgroup.* Section 1.1502-95(d)(2)(ii) and §1.1502-95(d)(3), *Example 3* apply to corporations that cease to bear a relationship described in section 1504(a)(1) to a loss subgroup parent in taxable years for which the due date of the income tax return (without extensions) is after June 25, 1999.

(ii) *Expiration of 5-year period.* Section 1.1502-95(d)(2)(iii) applies with respect to the day after the last day of any 5 consecutive year period described in that section that ends in a taxable year for which the due date of the income tax return (without extensions) is after June 25, 1999.

(4) *Reattribution of net operating loss carryovers under §1.1502-20(g).* Section 1.1502-96(d) applies to reattributions of net operating loss carryovers (or capital loss carryovers) in taxable years for which the due date of the income tax return (without extensions) is after June 25, 1999; except that the election under §1.1502-96(d)(5) (relating to an election to reattribute section 382 limitation) can be made with any election under §1.1502-20(g)(4) to reattribute to the common parent a net operating loss or net capital loss that is timely filed on or after June 25, 1999.

(5) *Election to apportion net unrealized built-in gain.* In the case of corporations that cease to be members of a loss group (or loss subgroup) before June 25, 1999 in a taxable year for which the due date of the income tax return (without extensions) is after June 25, 1999, §1.1502-95(a), (b), (c), and (f) apply to those corporations if the common parent makes the election described in the second sentence of paragraph (c)(1) of §1.1502-95 in the time and manner prescribed in paragraph (f) of §1.1502-95.

(c) *Testing period may include a period beginning before June 25, 1999*—(1) *In general.* A testing period for purposes of §§1.1502–91 through 1.1502–96 and 1.1502–98 may include a period beginning before June 25, 1999. Thus, for example, in applying §1.1502–92(b)(1)(i) (relating to the determination of an ownership change of a loss group), the determination of the lowest percentage of ownership interest of any 5-percent shareholder of the common parent during a testing period ending on a testing date occurring on or after June 25, 1999 takes into account the period beginning before June 25, 1999, except to the extent that the period is more than 3 years before the testing date or is otherwise before the beginning of the testing period. See §1.1502–92(b)(1).

(2) *Transition rule for net unrealized built-in loss.* A loss group (or loss subgroup) that has a net unrealized built-in loss on a testing date on or after June 25, 1999 may apply §1.1502–91A(g) (and §1.1502–96A(a) as it relates to §1.1502–91A(g)) for the period ending on the day before June 25, 1999 to determine under §1.382–2T(d)(ii)(A) the earliest date that its testing period begins (treating the day before June 25, 1999 as the end of a taxable year.) Thus, for example, if a consolidated group with no net operating losses has a net unrealized built-in loss determined under §1.1502–91(g) on a testing date after June 25, 1999, but, under §1.1502–91A(g), does not have a net unrealized built-in loss for the period ending on the day before June 25, 1999, the group’s testing period begins no earlier than June 25, 1999.

PART 602—OMB CONTROL NUMBERS UNDER THE PAPERWORK REDUCTION ACT

Par. 14. The authority citation for part 602 continues to read as follows:

Authority: 26 U.S.C. 7805.

Par. 15. In §602.101, paragraph (b) is amended by removing the entry for §1.1502–95T, revising the entry for §1.1502–20, and adding entries in numerical order to the table to read as follows:

§602.101 OMB Control numbers.

CFR part or section where identified and described	Current OMB control No.
* * * * *	
1.1502–20	1545–1160 1545–1218
* * * * *	
1.1502–95	1545–1218
1.1502–96	1545–1218
1.1502–95A	1545–1218
* * * * *	

John M. Dalrymple,
*Acting Deputy Commissioner
of Internal Revenue.*

Approved June 18, 1999.

Donald C. Lubick,
*Assistant Secretary of
the Treasury.*

(Filed by the Office of the Federal Register on June 25, 1999, 1:27 p.m., and published in the issue of the Federal Register for July 2, 1999, 64 F.R. 36116)

* * * * *

(b) * * *